

Carnet de profils en travers - RD

Axe : Axe
 N° profil : 7
 Pk : 13.906m

 Z Tn : 489.6
 Z Projet : 489.66

 Section remblais : 0.0
 Section déblais : 4.03

 Echelle X : 1/50
 Echelle Z : 1/50

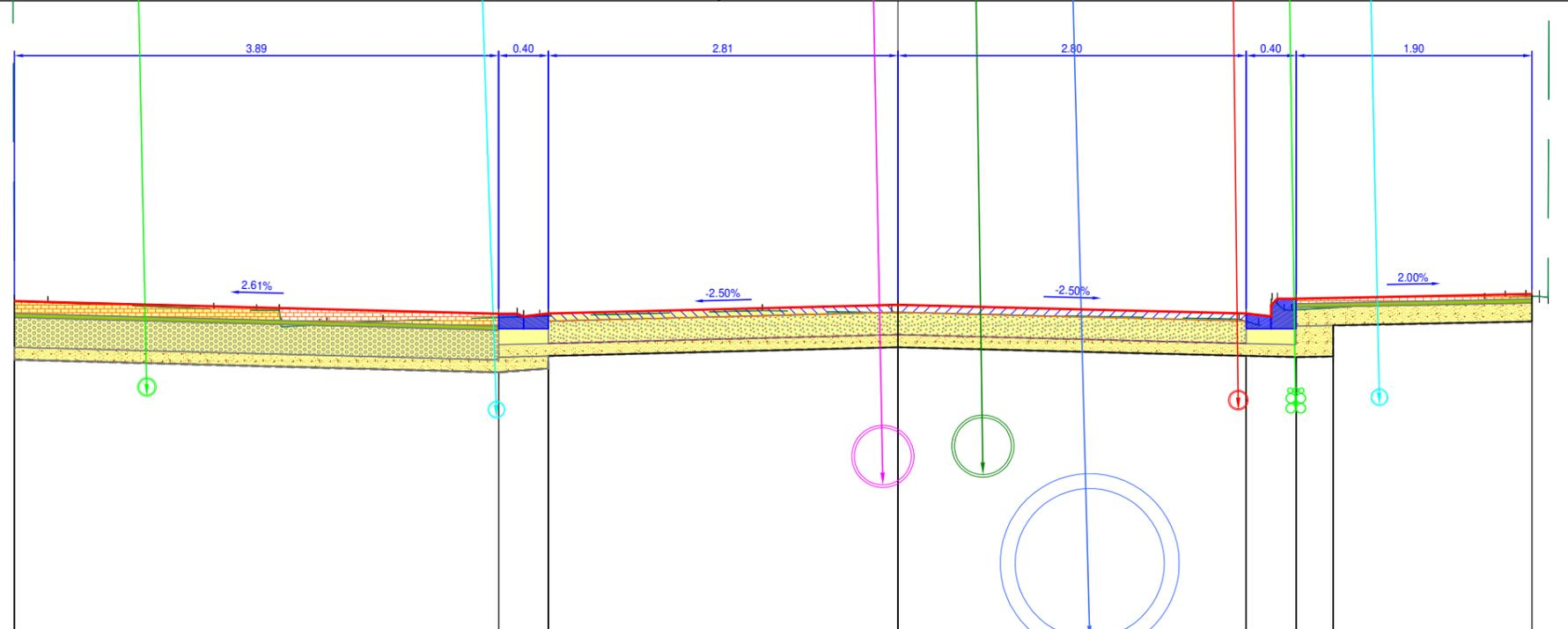

Plan Comp : 487.0

Terrain	Z	-8.280	-7.403	-7.122	-6.835	-5.500	-5.156	-4.874	-4.650	-4.451	-3.210	-2.880	-1.089	-0.051	2.742	2.901	3.008	3.105	4.716	4.885	5.048	5.156	5.228	5.651	
	D	0.667	0.878	0.832	1.334	0.345	0.309	0.451	1.260	2.880	1.791	1.038	0.000	2.742	2.742	2.901	3.008	3.105	1.548	4.716	4.885	5.048	5.156	5.228	5.651
GC	Z		489.32	489.36							489.46														
	D		-7.103	-7.103			3.893				-3.210														4.702
Projet	Z		489.69	489.69							489.59			489.66		489.59	489.57	489.62							
	D		-7.103	-7.103			3.893				-3.210	-3.060	-3.070	-2.810	0.000	2.800	3.000	3.200	1.897						5.097
Ecart entre Projet - Terrain			-0.00	-0.00							-0.03	-0.02	0.06		-0.06	-0.09									-0.02
BBSG	Z										489.53		489.66		489.53	489.53									
	D										-2.810		0.000		2.800	2.800									
GB	Z										489.35		489.60		489.35	489.35									
	D										-2.810		0.000		2.800	2.800									
Dalles	Z		489.32	489.32							489.59		489.66		489.35	489.49	489.35								
	D		-7.103	-7.103			3.893				-3.210		6.410		3.200	3.200	3.500	1.897							5.097
GNT 20	Z		489.22	489.22							489.34		489.42		489.35	489.49	489.35								
	D		-7.103	-7.103			3.893				-3.210	-0.400	2.810	0.000	2.800	3.200	3.500	1.597							5.097
Fond de forme	Z		489.69	489.69							489.12		489.22		489.24	489.24	489.25								
	D		-7.103	-7.103			3.893				-3.210	-0.400	2.810	0.000	3.200	3.500	1.597								5.097

Carnet de profils en travers - RD

Axe : Axe
 N° profil : 8
 Pk : 16.204m

Z Tn : 489.6
 Z Projet : 489.68

Section remblais : 0.0
 Section déblais : 4.11

Echelle X : 1/50
 Echelle Z : 1/50

Plan Comp : 487.0

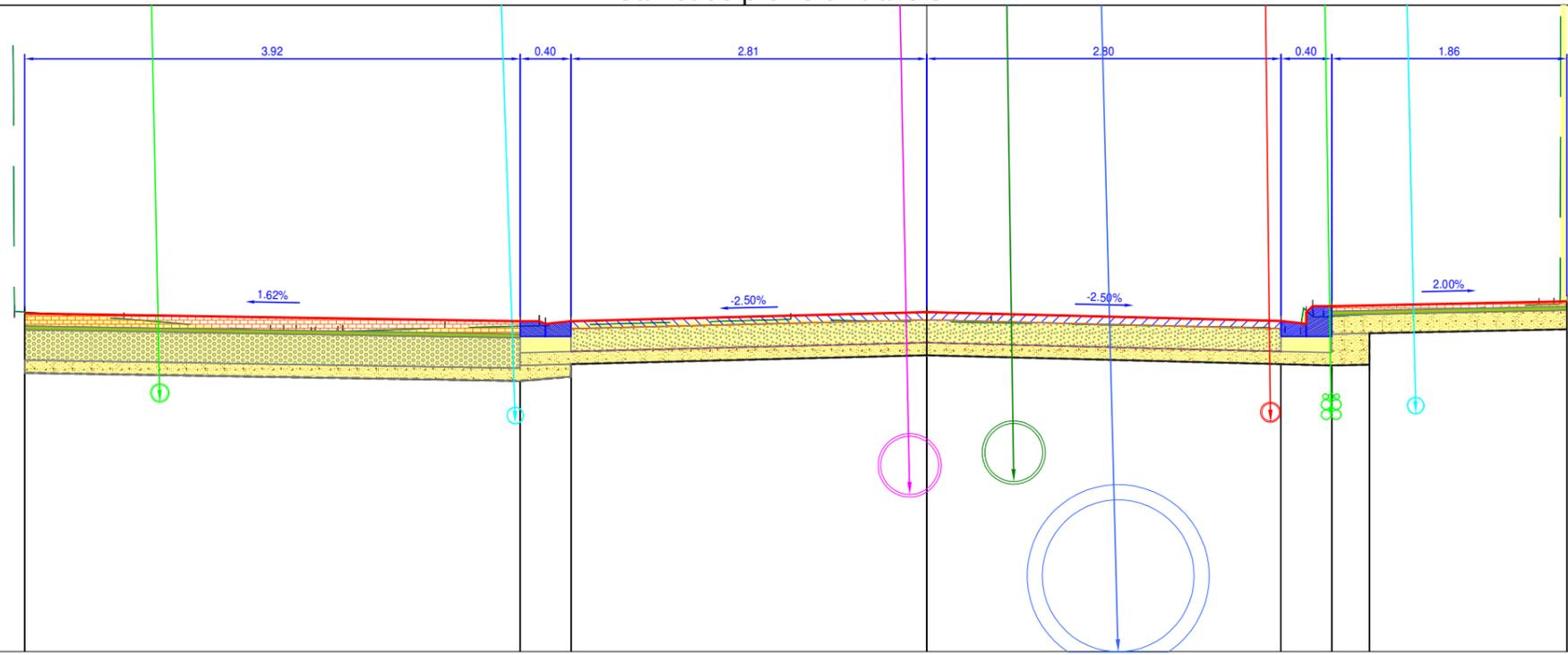

Terrain	Z	-8.613	-8.389	0.778	0.303	0.784	-6.346	1.158	-5.187	-3.983	-4.883	-4.654	0.808	-3.808	-1.075	0.000	0.510	2.198	2.708	2.883	2.959	3.039	3.137	1.703	4.840	4.957	5.059	5.343	0.933	6.276	4.067		
	D	-494.00	-494.00	-494.00	-494.00	-489.68	-489.63	-489.53	-489.53	-489.53	-489.51	-489.52	-489.55	-489.62	-489.60	-489.60	-489.56	-489.52	-489.50	-489.50	-489.64	-489.64	-489.74	-489.74	-494.00	-494.00	-494.00	-494.00	-494.00	-494.00	-494.00		
GC	Z				489.30	489.54							489.48																				
	D				-7.130	-7.130			3.917				-3.213																				
Projet	Z				489.67	489.61			489.61	489.61	489.59	489.61	489.68			489.61	489.59	489.68	489.73														
	D				-7.130	-3.083	-3.073	-2.813	-2.813	2.813	2.813	0.000	2.800	2.800	3.000	3.050	3.200	1.859	5.059														
Ecart entre Projet - Terrain				-0.01					-0.04	-0.03			-0.07			-0.08	-0.08																
BBSG	Z				489.57	489.61			489.55	489.61	489.55	489.61	489.68			489.55	489.55	489.61	489.73														
	D				-7.130	-3.213	-2.813	2.813	2.813	0.000	2.800	2.800	2.800	2.800	3.000	3.200	1.859	5.059															
GB	Z				489.37	489.55			489.37	489.55	489.37	489.55	489.62			489.37	489.55	489.61	489.73														
	D				-7.130	-3.213	-2.813	2.813	2.813	0.000	2.800	2.800	2.800	2.800	3.000	3.200	1.859	5.059															
Dalles	Z				489.20	489.26			489.26	489.36	489.27	489.37	489.44			489.37	489.66	489.51	489.51														
	D				-7.130	-3.213	-2.813	2.813	2.813	0.000	2.800	2.800	2.800	2.800	3.000	3.200	1.859	5.059															
GNT 20	Z				489.14	489.26			489.26	489.36	489.27	489.37	489.44			489.37	489.66	489.51	489.51														
	D				-7.130	-3.213	-2.813	2.813	2.813	0.000	2.800	2.800	2.800	2.800	3.000	3.200	1.559	5.059															
Fond de forme	Z				489.14	489.26			489.26	489.36	489.27	489.37	489.44			489.37	489.66	489.51	489.51														
	D				-7.130	-3.213	-2.813	2.813	2.813	0.000	2.800	2.800	2.800	2.800	3.000	3.200	1.559	5.059															

Carnet de profils en travers - RD

Axe : Axe
 N° profil : 14
 Pk : 34.699m

Z Tn : 489.74
 Z Projet : 489.91

Section remblais : 0.0
 Section déblais : 2.1

Echelle X : 1/50
 Echelle Z : 1/50

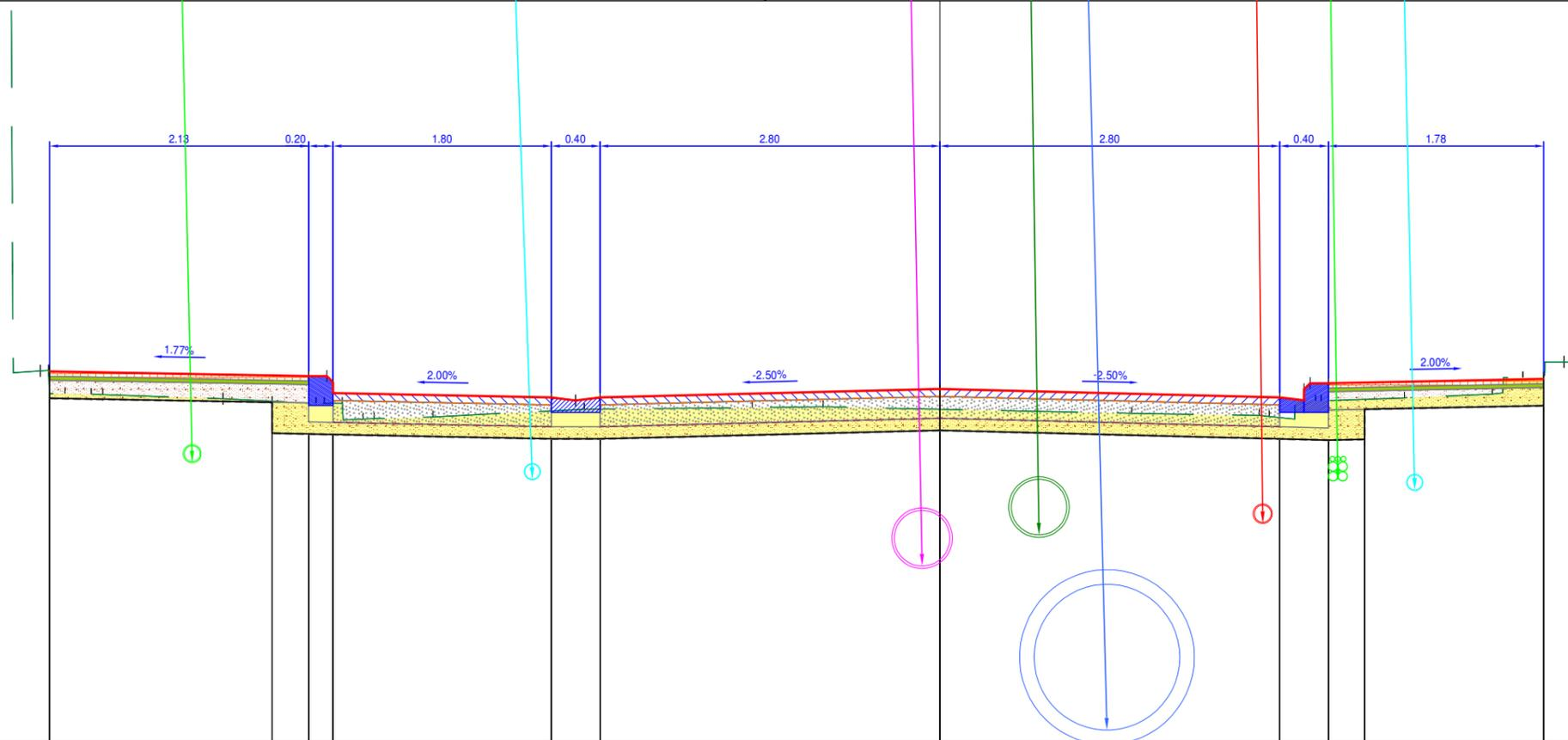

Plan Comp : 487.0

Terrain	Z	-8.237	-8.113	-7.672	-7.410	-7.343	-6.990	-6.886	-5.905	-5.071	-4.923	-4.751	-4.660	-4.175	-2.950	-1.544	-0.962	0.000	1.579	1.579	2.631	2.713	2.924	3.095	3.141	3.828	4.552	4.637	4.804	4.975	5.142	5.281	6.309	8.316			
	D	0.440	0.440	0.440	0.440	0.440	0.440	0.440	0.991	0.766	0.485	0.485	0.485	0.485	1.246	1.385	0.582	0.962	0.000	1.579	1.579	2.631	2.713	2.924	3.095	3.141	3.828	4.552	4.637	4.804	4.975	5.142	5.281	6.309	8.316		
Projet	Z																																				
	D																																				
Ecart entre Projet - Terrain																																					
BBSG	Z																																				
	D																																				
GB	Z																																				
	D																																				
Dalles	Z																																				
	D																																				
GNT 20	Z																																				
	D																																				
Fond de forme	Z																																				
	D																																				

Carnet de profils en travers - RD

Axe : Axe
 N° profil : 23
 Pk : 55.410m

 Z Tn : 490.13
 Z Projet : 490.4

 Section remblais : 0.08
 Section déblais : 1.13

 Echelle X : 1/50
 Echelle Z : 1/50

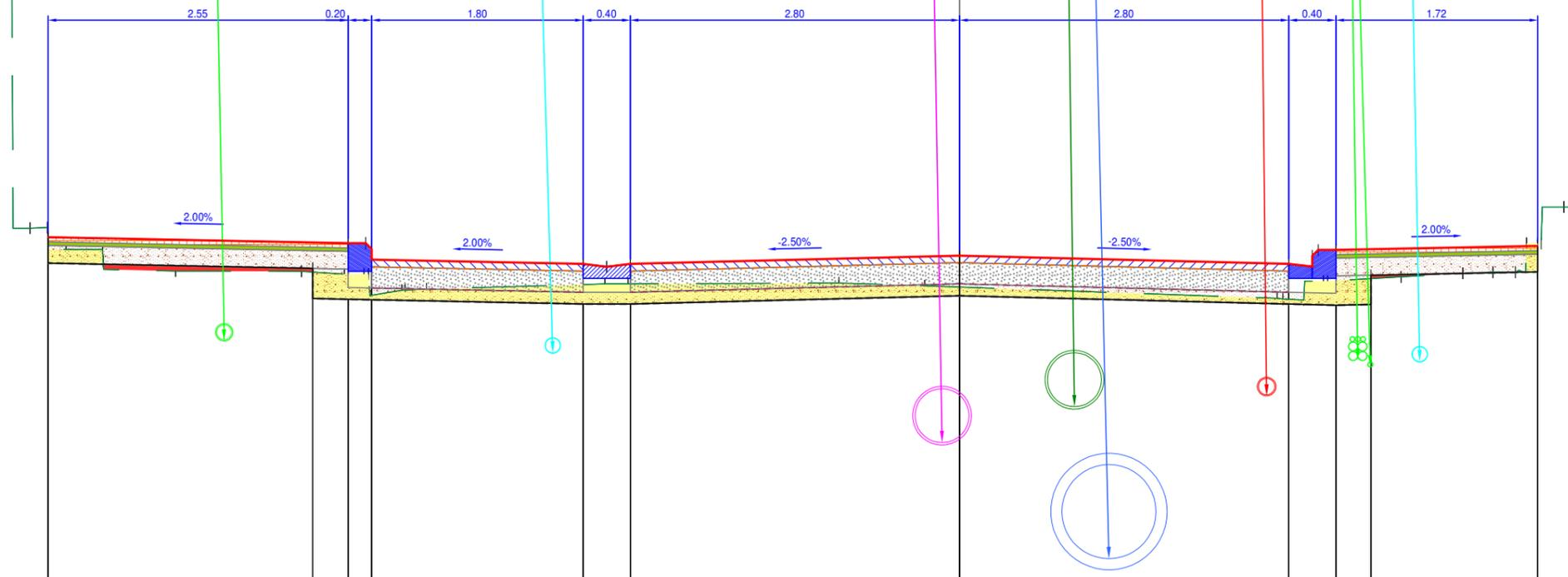

Plan Comp : 487.5

Terrain	Z	-8.497	-8.063	-7.905	-7.758	-7.598	-6.666	-5.597	-5.231	-5.055	-4.718	-4.533	-3.016	-2.820	-1.026	-0.296	0.000	2.702	2.702	2.927	3.096	3.130	3.755	4.280	4.536	4.728	4.822	4.918	5.139	5.206	7.201	8.348	8.674	496.00	496.00	496.00				
	D	0.434							0.365																															
Projet	Z		-490.55						-490.50	-490.50	-490.50		-490.33	-490.30	-490.33		-490.40			-490.33	-490.30	-490.44																		
	D		-7.751				2.551		-5.200	-5.050			-3.200	-3.000	-2.800		0.000		2.800	2.800	3.000	3.200		1.718																
Ecart entre Projet - Terrain			-0.05						-0.26	-0.30			-0.17				-0.27			-0.30	-0.26																			
BBSG	Z								490.30	490.36			490.33	490.33	490.27		490.40			490.33	490.27																			
	D								-5.000		1.800		-3.200	-2.800		2.800		2.800		2.800	2.800			1.718																
GB	Z								490.12	490.36			490.27	490.33	490.09		490.34			490.27	490.09																			
	D								-5.000		1.800		-3.200	-2.800		2.800		2.800		2.800	2.800			1.718																
Dalles	Z		490.51	490.55					490.50				490.09	490.09		490.16			490.09	490.37	490.38																			
	D		-7.751		2.551			-5.200			8.400					0.000		2.800	3.200	3.500			1.718																	
GNT 20	Z		490.48	490.33				490.29	490.28				490.09	490.09		490.16			490.09	490.37	490.38																			
	D		-7.751		2.251		-5.500	-5.200	-5.000		2.800		-3.200	-2.800		0.000		2.800	3.200	3.500			1.418																	
Fond de forme	Z		490.55	490.33				490.29	490.28				490.09	490.09		490.16			490.09	490.37	490.38																			
	D		-7.751		2.251		-5.500	-5.200	-5.000		2.800		-3.200	-2.800		0.000		3.200	3.500				1.418																	

Carnet de profils en travers - RD

Axe : Axe
 N° profil : 24
 Pk : 58.574m

Z Tn : 490.2
 Z Projet : 490.48

Section remblais : 0.13
 Section déblais : 0.93

Echelle X : 1/50
 Echelle Z : 1/50

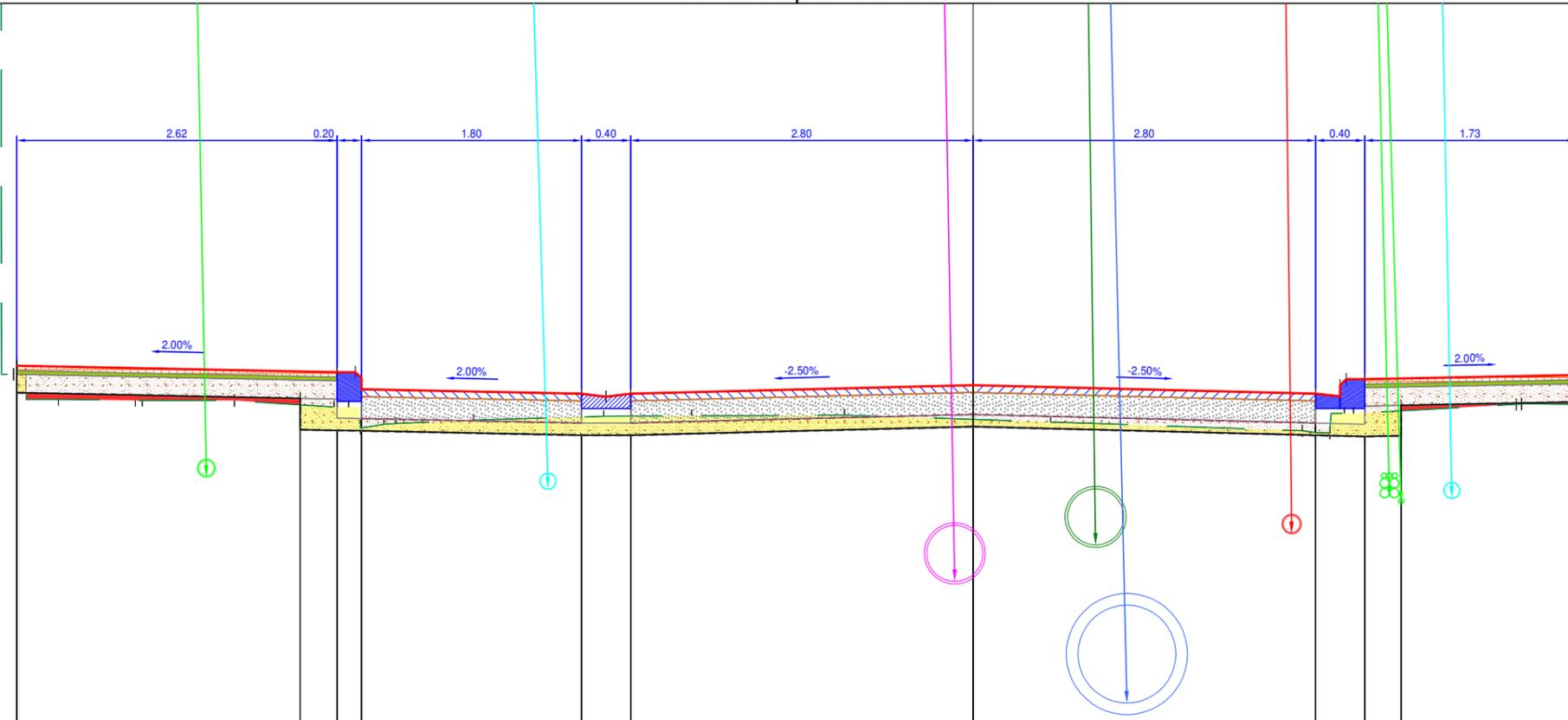

Plan Comp : 487.5

Terrain	Z	-7.946	-7.844	-7.746	-7.743	-7.478	-6.039	-5.223	-5.106	-5.008	-4.816	-4.721	-4.082	-3.019	-2.300	-1.051	0.000	0.633	0.633	2.691	2.797	2.918	3.050	3.170	4.442	4.484	4.913	4.924	5.166	5.244	5.756	6.493	7.164		
	D	0.875	0.629	0.752	0.816	0.639	0.816	0.639	0.639	0.639	0.639	0.639	0.639	0.639	0.639	0.639	0.639	0.639	0.639	0.639	2.691	2.797	2.918	3.050	3.170	4.442	4.484	4.913	4.924	5.166	5.244	5.756	6.493	7.164	
Projet	Z	-7.818	-7.818	-7.818	-7.818	-7.818	-7.818	-7.818	-7.818	-7.818	-7.818	-7.818	-7.818	-7.818	-7.818	-7.818	-7.818	-7.818	-7.818	-7.818	-7.818	-7.818	-7.818	-7.818	-7.818	-7.818	-7.818	-7.818	-7.818	-7.818	-7.818	-7.818	-7.818	-7.818	-7.818
	D	0.875	0.629	0.752	0.816	0.639	0.816	0.639	0.639	0.639	0.639	0.639	0.639	0.639	0.639	0.639	0.639	0.639	0.639	0.639	2.691	2.797	2.918	3.050	3.170	4.442	4.484	4.913	4.924	5.166	5.244	5.756	6.493	7.164	
Ecart entre Projet - Terrain		-0.07	0.000	0.000	0.000	0.000	0.000	0.000	0.000	0.000	0.000	0.000	0.000	0.000	0.000	0.000	0.000	0.000	0.000	0.000	0.000	0.000	0.000	0.000	0.000	0.000	0.000	0.000	0.000	0.000	0.000	0.000	0.000	0.000	
BBSG	Z	-7.818	-7.818	-7.818	-7.818	-7.818	-7.818	-7.818	-7.818	-7.818	-7.818	-7.818	-7.818	-7.818	-7.818	-7.818	-7.818	-7.818	-7.818	-7.818	-7.818	-7.818	-7.818	-7.818	-7.818	-7.818	-7.818	-7.818	-7.818	-7.818	-7.818	-7.818	-7.818	-7.818	-7.818
	D	0.875	0.629	0.752	0.816	0.639	0.816	0.639	0.639	0.639	0.639	0.639	0.639	0.639	0.639	0.639	0.639	0.639	0.639	0.639	2.691	2.797	2.918	3.050	3.170	4.442	4.484	4.913	4.924	5.166	5.244	5.756	6.493	7.164	
GB	Z	-7.818	-7.818	-7.818	-7.818	-7.818	-7.818	-7.818	-7.818	-7.818	-7.818	-7.818	-7.818	-7.818	-7.818	-7.818	-7.818	-7.818	-7.818	-7.818	-7.818	-7.818	-7.818	-7.818	-7.818	-7.818	-7.818	-7.818	-7.818	-7.818	-7.818	-7.818	-7.818	-7.818	-7.818
	D	0.875	0.629	0.752	0.816	0.639	0.816	0.639	0.639	0.639	0.639	0.639	0.639	0.639	0.639	0.639	0.639	0.639	0.639	0.639	2.691	2.797	2.918	3.050	3.170	4.442	4.484	4.913	4.924	5.166	5.244	5.756	6.493	7.164	
Dalles	Z	-7.818	-7.818	-7.818	-7.818	-7.818	-7.818	-7.818	-7.818	-7.818	-7.818	-7.818	-7.818	-7.818	-7.818	-7.818	-7.818	-7.818	-7.818	-7.818	-7.818	-7.818	-7.818	-7.818	-7.818	-7.818	-7.818	-7.818	-7.818	-7.818	-7.818	-7.818	-7.818	-7.818	-7.818
	D	0.875	0.629	0.752	0.816	0.639	0.816	0.639	0.639	0.639	0.639	0.639	0.639	0.639	0.639	0.639	0.639	0.639	0.639	0.639	2.691	2.797	2.918	3.050	3.170	4.442	4.484	4.913	4.924	5.166	5.244	5.756	6.493	7.164	
GNT 20	Z	-7.818	-7.818	-7.818	-7.818	-7.818	-7.818	-7.818	-7.818	-7.818	-7.818	-7.818	-7.818	-7.818	-7.818	-7.818	-7.818	-7.818	-7.818	-7.818	-7.818	-7.818	-7.818	-7.818	-7.818	-7.818	-7.818	-7.818	-7.818	-7.818	-7.818	-7.818	-7.818	-7.818	-7.818
	D	0.875	0.629	0.752	0.816	0.639	0.816	0.639	0.639	0.639	0.639	0.639	0.639	0.639	0.639	0.639	0.639	0.639	0.639	0.639	2.691	2.797	2.918	3.050	3.170	4.442	4.484	4.913	4.924	5.166	5.244	5.756	6.493	7.164	
Fond de forme	Z	-7.818	-7.818	-7.818	-7.818	-7.818	-7.818	-7.818	-7.818	-7.818	-7.818	-7.818	-7.818	-7.818	-7.818	-7.818	-7.818	-7.818	-7.818	-7.818	-7.818	-7.818	-7.818	-7.818	-7.818	-7.818	-7.818	-7.818	-7.818	-7.818	-7.818	-7.818	-7.818	-7.818	-7.818
	D	0.875	0.629	0.752	0.816	0.639	0.816	0.639	0.639	0.639	0.639	0.639	0.639	0.639	0.639	0.639	0.639	0.639	0.639	0.639	2.691	2.797	2.918	3.050	3.170	4.442	4.484	4.913	4.924	5.166	5.244	5.756	6.493	7.164	

Carnet de profils en travers - RD

Axe : Axe
 N° profil : 25
 Pk : 60.000m

Z Tn : 490.23
 Z Projet : 490.51

Section remblais : 0.12
 Section déblais : 1.03

Echelle X : 1/50
 Echelle Z : 1/50

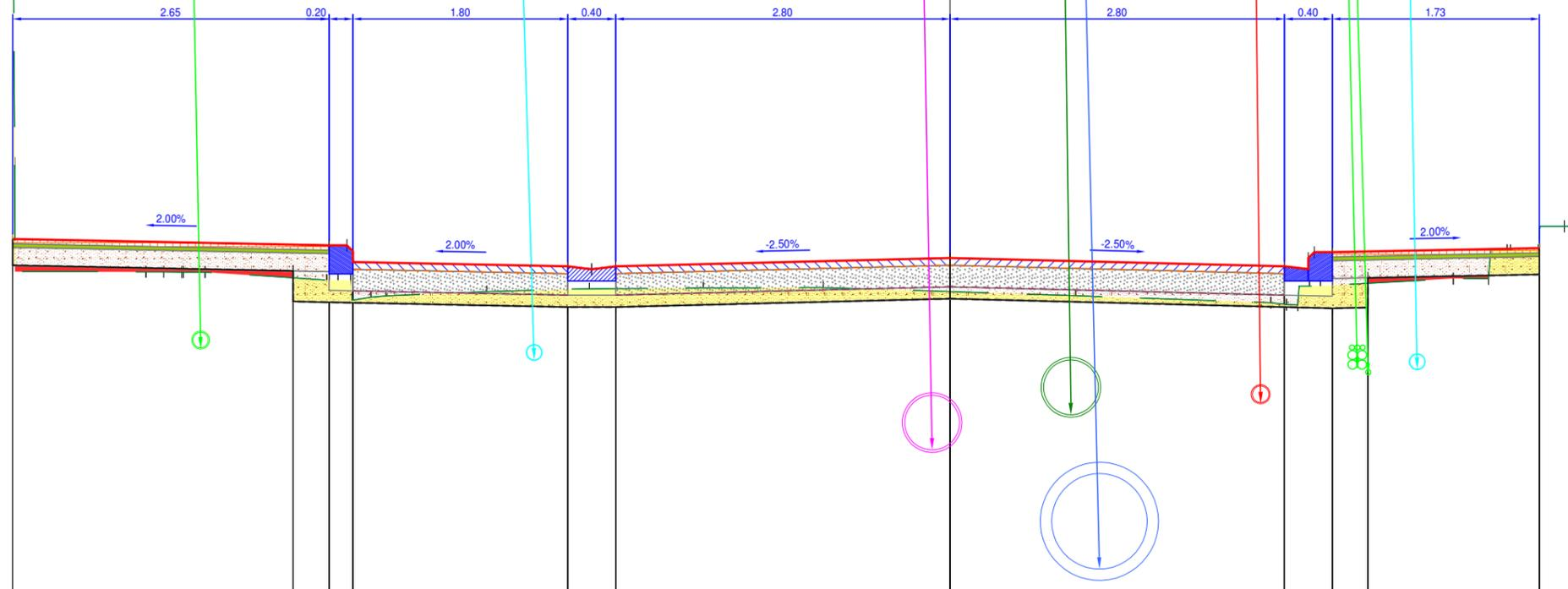

Plan Comp : 487.5

Terrain	Z	491.31	490.40	490.33	490.23	490.26	490.26	490.27	490.23	490.20	490.14	490.34	490.58	490.78	496.00	496.00
	D	7.848	6.733	5.219	3.878	3.021	2.066	1.062	0.000	1.052	2.686	4.216	4.509	4.934	5.510	6.350
Projet	Z	490.67	490.40	490.62	490.44	490.42	490.44	490.51	490.44	490.20	490.44	490.60	490.51	490.51	490.51	490.51
	D	7.848	2.648	5.200	1.800	3.200	2.800	0.000	2.800	2.800	3.050	4.934	3.050	3.200	4.934	4.094
Ecart entre Projet - Terrain		-3.33	2.648	-0.29	1.800	-0.32	1.800	0.28	0.000	2.800	-0.32	1.734	-0.28	-0.11	0.840	0.000
BBSG	Z			490.42	490.44	490.44	490.45	490.51	490.44	490.20	490.44	490.60	490.51	490.51	490.51	490.51
	D			5.000	3.200	2.800	0.000	2.800	2.800	2.800	3.050	4.934	3.050	3.200	4.934	4.094
GB	Z			490.42	490.44	490.44	490.45	490.51	490.44	490.20	490.44	490.60	490.51	490.51	490.51	490.51
	D			5.000	3.200	2.800	0.000	2.800	2.800	2.800	3.050	4.934	3.050	3.200	4.934	4.094
Dalles	Z	490.63		490.62							490.56			490.56		
	D	7.848	2.648	5.200	1.800	3.200	8.400	0.000	2.800	2.800	3.200	1.734	4.934	3.200	4.934	4.094
GNT 20	Z	490.45		490.41		490.20		490.27		490.20	490.34		490.20	490.38		
	D	7.848	2.348	5.500	1.800	3.200	2.800	0.000	2.800	2.800	3.200	1.434	4.934	3.500	4.934	4.094
Fond de forme	Z	490.45		490.14		490.10		490.17		490.10	490.09		490.10	490.38		
	D	7.848	2.348	5.500	1.800	3.200	2.800	0.000	2.800	3.200	1.434	4.934	3.500	4.934	4.094	4.094

Carnet de profils en travers - RD

Axe : Axe
 N° profil : 33
 Pk : 82.857m

 Z Tn : 490.73
 Z Projet : 490.84

 Section remblais : 0.0
 Section déblais : 3.16

 Echelle X : 1/50
 Echelle Z : 1/50

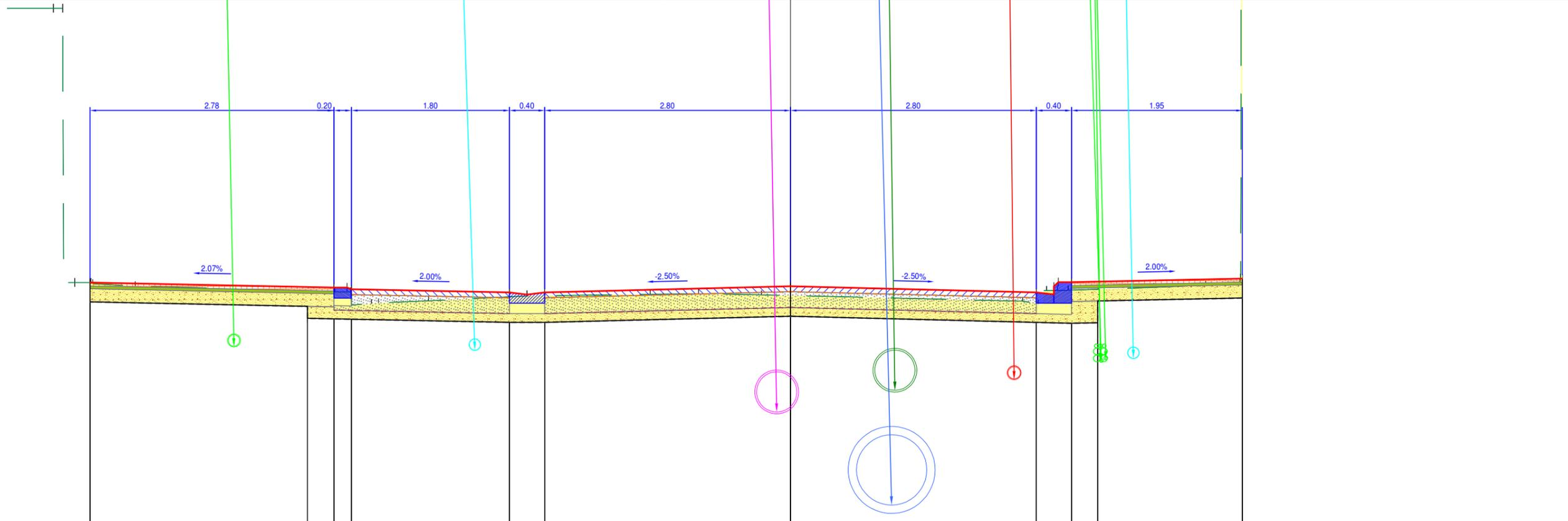

Plan Comp : 488.0

	Terrain		Projet		Ecart entre Projet - Terrain	BBSG		GB		Dalles		GNT 20		Fond de forme	
	Z	D	Z	D		Z	D	Z	D	Z	D	Z	D	Z	D
	494.00	-8.394	490.88	-7.978	-0.00	490.82	-5.200	490.71	-3.200	490.84	-7.978	490.66	-5.500	490.43	-3.200
	494.00	-8.288	490.88	-7.978	-0.00	490.82	-5.050	490.71	-3.200	490.84	-7.978	490.66	-5.500	490.43	-3.200
	490.88	-8.150	490.88	-7.978	-0.00	490.82	-5.000	490.71	-3.200	490.84	-7.978	490.66	-5.500	490.43	-3.200
	490.87	-7.964	490.88	-7.978	-0.01	490.82	-5.000	490.71	-3.200	490.84	-7.978	490.66	-5.500	490.43	-3.200
	490.84	-7.462	490.84	-7.978	-0.516	490.82	-5.000	490.71	-3.200	490.84	-7.978	490.66	-5.500	490.43	-3.200
	490.77	-5.189	490.77	-5.200	-0.021	490.82	-5.000	490.71	-3.200	490.84	-7.978	490.66	-5.500	490.43	-3.200
	490.73	-5.006	490.73	-5.000	-0.006	490.82	-5.000	490.71	-3.200	490.84	-7.978	490.66	-5.500	490.43	-3.200
	490.65	-4.772	490.65	-4.772	-0.000	490.82	-5.000	490.71	-3.200	490.84	-7.978	490.66	-5.500	490.43	-3.200
	490.67	-4.122	490.67	-4.122	-0.000	490.82	-5.000	490.71	-3.200	490.84	-7.978	490.66	-5.500	490.43	-3.200
	490.73	-2.999	490.73	-2.800	-0.199	490.82	-5.000	490.71	-3.200	490.84	-7.978	490.66	-5.500	490.43	-3.200
	490.75	-1.597	490.75	-1.597	-0.000	490.82	-5.000	490.71	-3.200	490.84	-7.978	490.66	-5.500	490.43	-3.200
	490.75	-1.046	490.75	-1.046	-0.000	490.82	-5.000	490.71	-3.200	490.84	-7.978	490.66	-5.500	490.43	-3.200
	490.74	-0.330	490.74	-0.330	-0.000	490.82	-5.000	490.71	-3.200	490.84	-7.978	490.66	-5.500	490.43	-3.200
	490.73	0.000	490.73	0.000	0.000	490.82	-5.000	490.71	-3.200	490.84	-7.978	490.66	-5.500	490.43	-3.200
	490.67	2.644	490.67	2.644	0.000	490.82	-5.000	490.71	-3.200	490.84	-7.978	490.66	-5.500	490.43	-3.200
	490.64	2.822	490.64	2.822	0.000	490.82	-5.000	490.71	-3.200	490.84	-7.978	490.66	-5.500	490.43	-3.200
	490.79	2.876	490.79	2.876	0.000	490.82	-5.000	490.71	-3.200	490.84	-7.978	490.66	-5.500	490.43	-3.200
	490.79	3.040	490.79	3.040	0.000	490.82	-5.000	490.71	-3.200	490.84	-7.978	490.66	-5.500	490.43	-3.200
	490.79	3.163	490.79	3.163	0.000	490.82	-5.000	490.71	-3.200	490.84	-7.978	490.66	-5.500	490.43	-3.200
	490.80	3.504	490.80	3.504	0.000	490.82	-5.000	490.71	-3.200	490.84	-7.978	490.66	-5.500	490.43	-3.200
	490.82	4.138	490.82	4.138	0.000	490.82	-5.000	490.71	-3.200	490.84	-7.978	490.66	-5.500	490.43	-3.200
	490.85	4.727	490.85	4.727	0.000	490.82	-5.000	490.71	-3.200	490.84	-7.978	490.66	-5.500	490.43	-3.200
	490.87	5.120	490.87	5.120	0.000	490.82	-5.000	490.71	-3.200	490.84	-7.978	490.66	-5.500	490.43	-3.200
	496.00	5.396	496.00	5.396	0.000	490.82	-5.000	490.71	-3.200	490.84	-7.978	490.66	-5.500	490.43	-3.200
	496.00	6.328	496.00	6.328	0.000	490.82	-5.000	490.71	-3.200	490.84	-7.978	490.66	-5.500	490.43	-3.200
	496.00	6.693	496.00	6.693	0.000	490.82	-5.000	490.71	-3.200	490.84	-7.978	490.66	-5.500	490.43	-3.200
	496.00	8.102	496.00	8.102	0.000	490.82	-5.000	490.71	-3.200	490.84	-7.978	490.66	-5.500	490.43	-3.200
	496.00	8.533	496.00	8.533	0.000	490.82	-5.000	490.71	-3.200	490.84	-7.978	490.66	-5.500	490.43	-3.200

Carnet de profils en travers - RD

Axe : Axe
 N° profil : 34
 Pk : 85.124m

 Z Tn : 490.78
 Z Projet : 490.86

 Section remblais : 0.0
 Section déblais : 3.22

 Echelle X : 1/50
 Echelle Z : 1/50

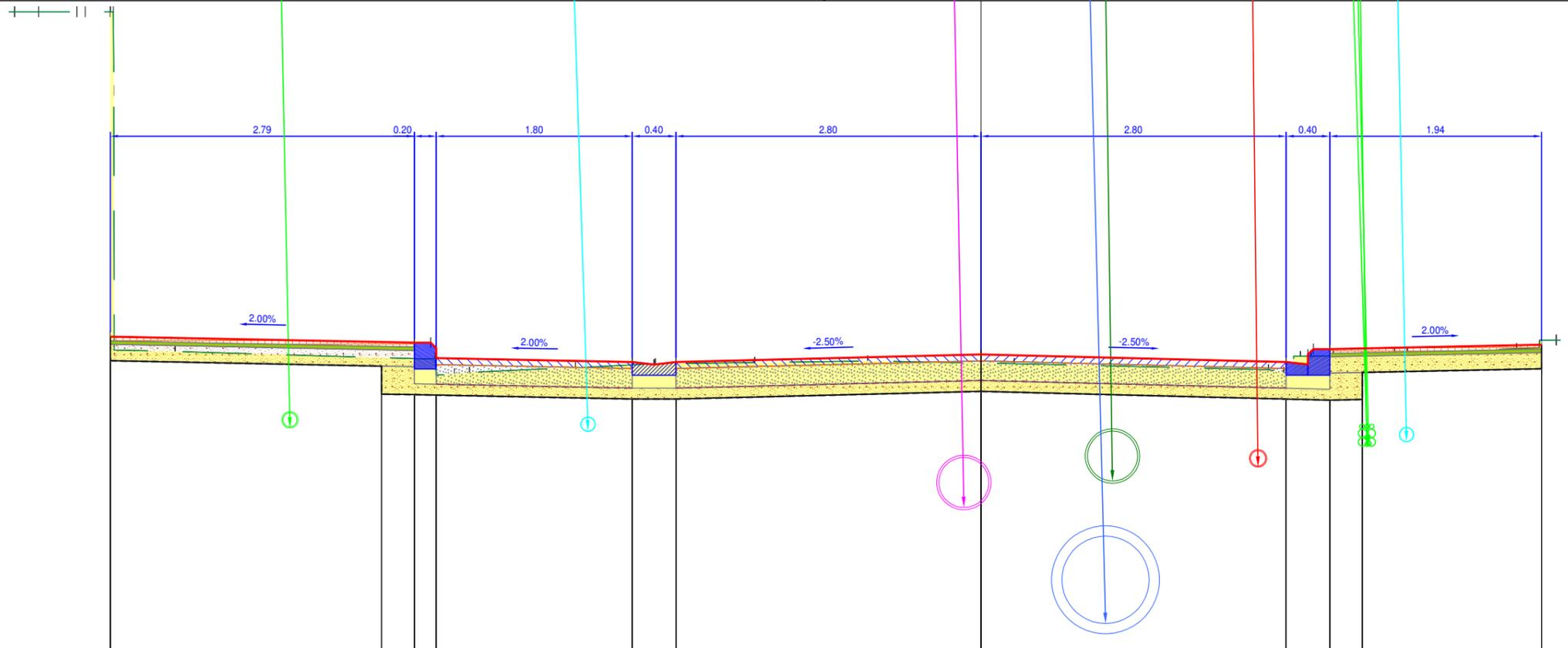

Plan Comp : 488.0

Terrain	Z	494.00	494.00	494.00	494.00	490.82	490.82	490.68	490.74	490.77	490.79	490.80	490.78	490.77	490.85	490.87	490.87	490.91	490.92	490.99	490.99	496.00	496.00							
	D	8.647	8.296	8.220	7.980	5.195	5.009	4.832	3.720	2.989	2.076	1.041	0.000	0.305	2.638	2.777	2.993	3.029	3.232	3.795	3.914	4.915	5.122	5.280	5.448	5.662	7.449	7.620	7.742	
Projet	Z	491.02	491.02	491.02	491.02	490.97	490.92	490.83	490.79	490.76	490.79	490.86	490.86	490.85	490.79	490.73	490.84	490.86	490.91	490.87	490.87	490.95	490.95	496.00	496.00	496.00	496.00	496.00	496.00	496.00
	D	7.990	7.990	7.990	7.990	5.200	5.050	5.000	3.200	3.000	2.800	0.000	0.000	2.800	2.800	3.000	3.050	3.200	3.200	3.795	3.914	4.915	5.122	5.280	5.448	5.662	7.449	7.620	7.742	
Ecart entre Projet - Terrain		-2.98	-2.98	-2.98	-2.98	-0.15	-0.16	-0.15	-0.15	-0.15	-0.15	-0.15	-0.15	-0.15	-0.10	-0.10	-0.10	-0.10	-0.10	-0.10	-0.10	-0.04	-0.04	-0.04	-0.04	-0.04	-0.04	-0.04	-0.04	
BBSG	Z	490.86	490.86	490.86	490.86	490.73	490.73	490.73	490.73	490.73	490.73	490.86	490.86	490.85	490.79	490.73	490.84	490.86	490.91	490.87	490.87	490.95	490.95	496.00	496.00	496.00	496.00	496.00	496.00	496.00
	D	7.990	7.990	7.990	7.990	5.000	5.000	5.000	3.200	3.000	2.800	0.000	0.000	2.800	2.800	3.000	3.050	3.200	3.200	3.795	3.914	4.915	5.122	5.280	5.448	5.662	7.449	7.620	7.742	
GB	Z	490.86	490.86	490.86	490.86	490.73	490.73	490.73	490.73	490.73	490.73	490.86	490.86	490.85	490.79	490.73	490.84	490.86	490.91	490.87	490.87	490.95	490.95	496.00	496.00	496.00	496.00	496.00	496.00	496.00
	D	7.990	7.990	7.990	7.990	5.000	5.000	5.000	3.200	3.000	2.800	0.000	0.000	2.800	2.800	3.000	3.050	3.200	3.200	3.795	3.914	4.915	5.122	5.280	5.448	5.662	7.449	7.620	7.742	
Dalles	Z	491.02	491.02	491.02	491.02	490.97	490.92	490.83	490.79	490.76	490.79	490.86	490.86	490.85	490.79	490.73	490.84	490.86	490.91	490.87	490.87	490.95	490.95	496.00	496.00	496.00	496.00	496.00	496.00	496.00
	D	7.990	7.990	7.990	7.990	5.200	5.050	5.000	3.200	3.000	2.800	0.000	0.000	2.800	2.800	3.000	3.050	3.200	3.200	3.795	3.914	4.915	5.122	5.280	5.448	5.662	7.449	7.620	7.742	
GNT 20	Z	490.86	490.86	490.86	490.86	490.75	490.75	490.75	490.75	490.75	490.75	490.86	490.86	490.85	490.79	490.73	490.84	490.86	490.91	490.87	490.87	490.95	490.95	496.00	496.00	496.00	496.00	496.00	496.00	496.00
	D	7.990	7.990	7.990	7.990	5.500	5.200	5.000	3.200	3.000	2.800	0.000	0.000	2.800	2.800	3.200	3.200	3.500	3.500	3.795	3.914	4.915	5.122	5.280	5.448	5.662	7.449	7.620	7.742	
Fond de forme	Z	491.02	491.02	491.02	491.02	490.45	490.45	490.45	490.45	490.45	490.45	490.86	490.86	490.85	490.79	490.73	490.84	490.86	490.91	490.87	490.87	490.95	490.95	496.00	496.00	496.00	496.00	496.00	496.00	496.00
	D	7.990	7.990	7.990	7.990	5.500	5.200	5.000	3.200	3.000	2.800	0.000	0.000	2.800	2.800	3.200	3.500	3.500	3.500	3.795	3.914	4.915	5.122	5.280	5.448	5.662	7.449	7.620	7.742	

Carnet de profils en travers - RD

Axe : Axe
 N° profil : 37
 Pk : 93.304m

 Z Tn : 490.95
 Z Projet : 490.96

 Section remblais : 0.0
 Section déblais : 3.96

 Echelle X : 1/50
 Echelle Z : 1/50

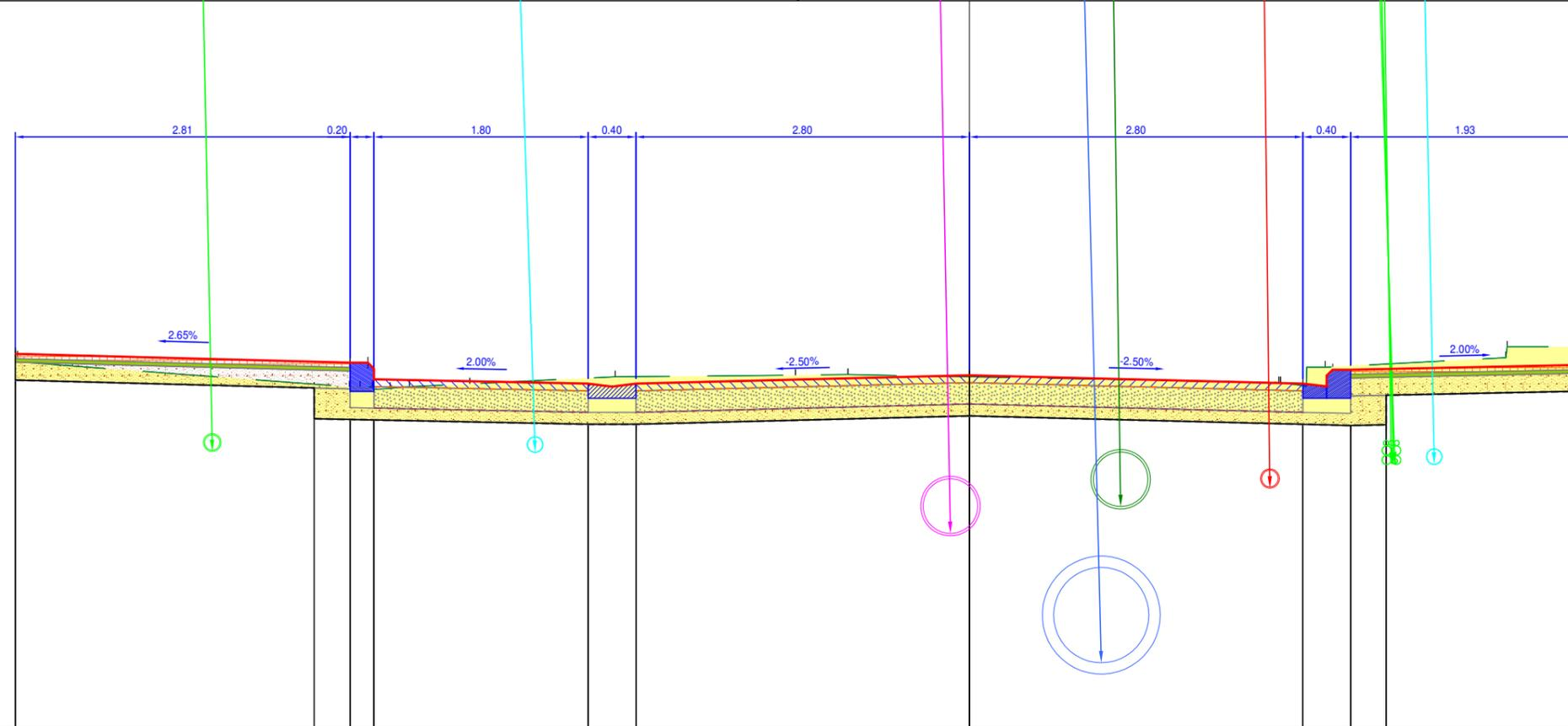

Plan Comp : 488.0

Terrain	Z	-8.317	-494.00	-8.151	-491.12	-8.009	-491.12	-7.993	-491.12	-7.530	-491.04	-5.205	-490.86	-5.178	-490.86	-5.011	-490.86	-4.864	-490.85	-4.701	-490.87	-4.194	-490.89	-2.973	-490.95	-1.459	-490.96	-1.021	-490.97	1.021	-490.95	2.599	2.599	480.90	2.829	490.87	2.987	491.03	1.516	4.504	481.20	5.127	491.20	5.381	496.00	5.442	496.00	5.610	496.00				
	D	0.540		0.463		2.325		5.205		5.011		0.507		4.194		1.222		2.973		1.514		1.459		0.439		1.021		0.000		2.599		2.599		2.829		2.829		2.987		1.516		4.504		5.127		5.381		5.610		4.871			
Projet	Z	-8.317	-494.00	-8.151	-491.12	-8.010	-491.14	-7.993	-491.14	-7.530	-491.04	-5.200	-491.07	-5.178	-491.07	-5.050	-491.07	-4.864	-491.02	-4.701	-490.87	-4.194	-490.89	-3.200	-490.89	-3.000	-490.86	-2.800	-490.89	0.000	-490.96	2.800	490.89	2.800	490.87	3.050	490.96	3.200	491.01	1.516	4.504	481.20	5.127	491.05	5.381	496.00	5.442	496.00	5.610	496.00			
	D	0.540		0.463		2.810		5.200		5.050		1.800		3.200		3.000		2.800		2.800		2.800		2.800		2.800		0.000		2.800		2.800		2.800		3.050		3.200		1.927		5.127		5.381		5.610		4.871					
Ecart entre Projet - Terrain			-0.02			2.810		-0.20		-0.08		1.800		-3.200		-3.000		-2.800		-2.800		-0.06		0.000		0.000		0.000		-0.01		2.800		2.800		2.800		2.800		-0.02		-0.03		-0.15									
BBSG	Z																																																				
	D																																																				
GB	Z																																																				
	D																																																				
Dalles	Z																																																				
	D																																																				
GNT 20	Z																																																				
	D																																																				
Fond de forme	Z																																																				
	D																																																				

Carnet de profils en travers - RD

Axe : Axe
 N° profil : 38
 Pk : 95.339m

 Z Tn : 490.99
 Z Projet : 491.0

 Section remblais : 0.0
 Section déblais : 4.53

 Echelle X : 1/50
 Echelle Z : 1/50

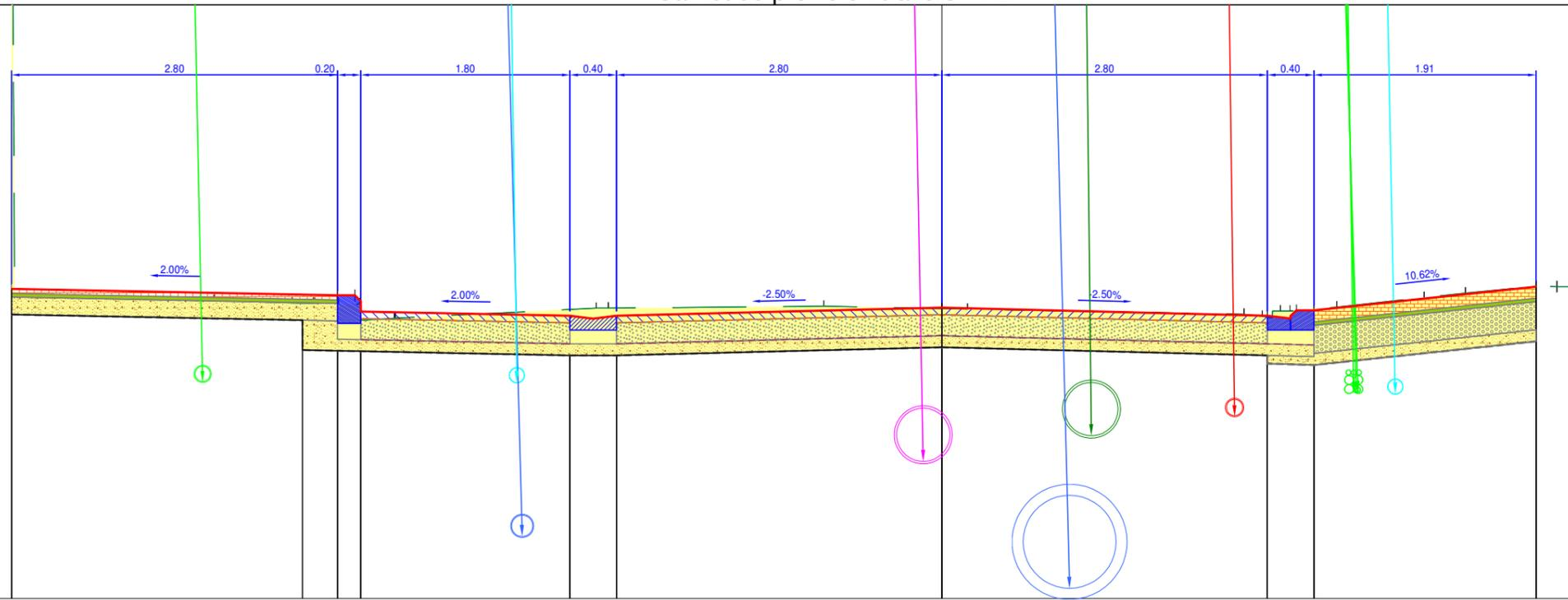

Terrain	Z	494.00	494.00	494.00	494.00	491.06	491.04	491.04	491.03	491.03	490.91	491.00	490.99	491.00	490.99	490.99	490.94	490.93	490.97	491.00	491.09	491.12	491.18	491.18	491.18	491.33	496.00	
	D	0.374	0.374	0.374	0.374	1.730	0.671	0.671	0.671	0.671	1.728	0.671	0.671	0.671	0.671	0.671	0.671	0.671	0.671	0.671	0.671	0.671	0.671	0.671	0.671	0.671	0.671	0.671
GC	Z																											
	D																											
Projet	Z	491.16	491.16	491.16	491.16	491.11	491.11	491.11	491.11	491.06	490.93	490.90	490.93	491.00	490.93	490.93	490.93	490.93	490.93	490.93	490.93	490.93	490.93	490.93	490.93	490.93	490.93	490.93
	D	8.004	8.004	8.004	8.004	2.804	1.800	1.800	1.800	1.800	2.800	2.800	2.800	2.800	2.800	2.800	2.800	2.800	2.800	2.800	2.800	2.800	2.800	2.800	2.800	2.800	2.800	2.800
Ecart entre Projet - Terrain		-2.84	-2.84	-2.84	-2.84	-0.07	-0.01	-0.01	-0.01	-0.07	0.00	0.00	0.00	0.00	0.00	0.00	0.00	0.00	0.00	0.00	0.00	0.00	0.00	0.00	0.00	0.00	0.00	
BBSG	Z																											
	D																											
GB	Z																											
	D																											
Dalles	Z	491.16	491.16	491.16	491.16	491.11	491.11	491.11	491.11	491.06	490.93	490.90	490.93	491.00	490.93	490.93	490.93	490.93	490.93	490.93	490.93	490.93	490.93	490.93	490.93	490.93	490.93	490.93
	D	8.004	8.004	8.004	8.004	2.804	1.800	1.800	1.800	1.800	2.800	2.800	2.800	2.800	2.800	2.800	2.800	2.800	2.800	2.800	2.800	2.800	2.800	2.800	2.800	2.800	2.800	2.800
GNT 20	Z	490.94	490.94	490.94	490.94	490.89	490.89	490.89	490.89	490.73	490.69	490.69	490.69	490.76	490.69	490.69	490.69	490.69	490.69	490.69	490.69	490.69	490.69	490.69	490.69	490.69	490.69	490.69
	D	8.004	8.004	8.004	8.004	2.504	1.800	1.800	1.800	1.800	2.800	2.800	2.800	2.800	2.800	2.800	2.800	2.800	2.800	2.800	2.800	2.800	2.800	2.800	2.800	2.800	2.800	2.800
Fond de forme	Z	490.94	490.94	490.94	490.94	490.89	490.89	490.89	490.89	490.73	490.69	490.69	490.69	490.76	490.69	490.69	490.69	490.69	490.69	490.69	490.69	490.69	490.69	490.69	490.69	490.69	490.69	490.69
	D	8.004	8.004	8.004	8.004	2.504	1.800	1.800	1.800	1.800	2.800	2.800	2.800	2.800	2.800	2.800	2.800	2.800	2.800	2.800	2.800	2.800	2.800	2.800	2.800	2.800	2.800	2.800

Carnet de profils en travers - RD

Axe : Axe
 N° profil : 41
 Pk : 101.859m

 Z Tn : 491.15
 Z Projet : 491.17

 Section remblais : 0.0
 Section déblais : 3.97

 Echelle X : 1/50
 Echelle Z : 1/50

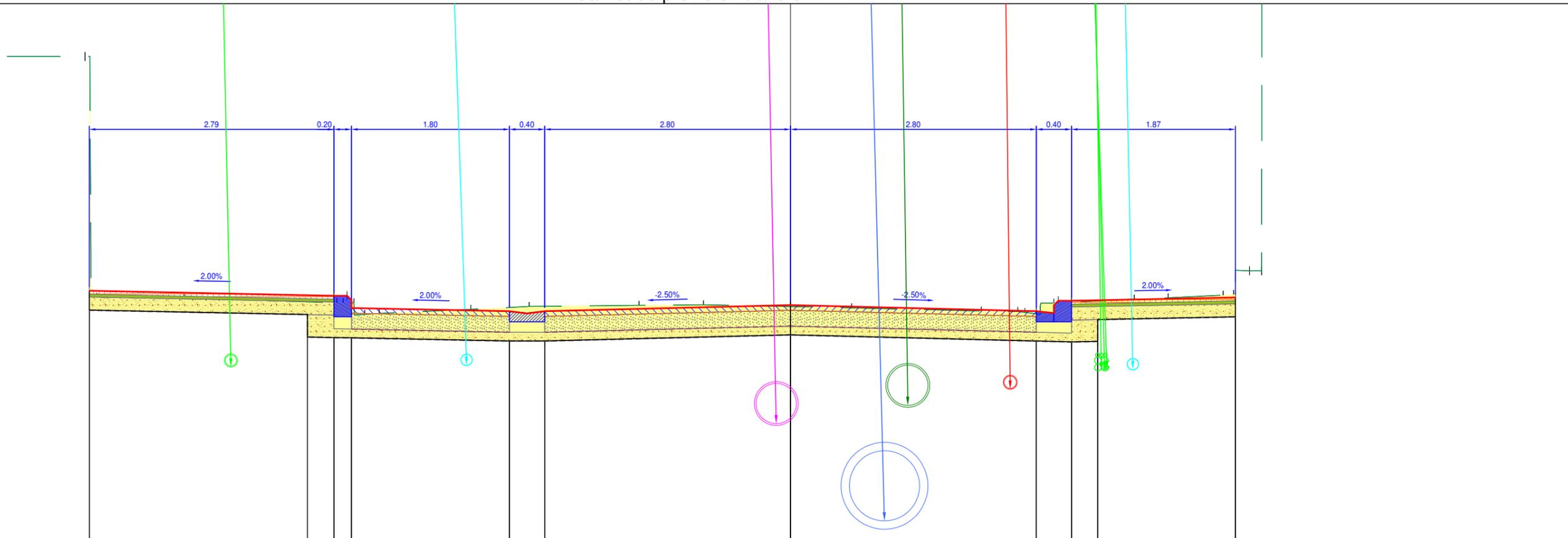

Plan Comp : 488.5

Terrain	Z	-8.035	-7.900	-6.907	-5.167	-4.972	-4.848	-3.639	-2.975	-1.725	-0.990	0.000	0.698	0.698	1.477	2.175	2.589	2.876	2.843	2.999	0.918	3.917	4.302	4.929	5.046	5.229	5.367	5.587	6.066	6.561	6.784	7.217
	D	0.993	1.740	1.800	1.800	1.800	1.800	1.800	2.800	2.800	2.800	2.800	2.800	2.800	2.800	2.800	3.050	3.200	3.200	3.200	0.918	0.385	0.626	5.067	5.067	5.229	5.367	5.587	6.066	6.561	6.784	7.217
Projet	Z	-7.986	-6.907	-5.200	-5.050	-3.200	-3.000	-2.800	-0.000	0.000	2.800	2.800	2.800	3.050	3.200	4.929	5.046	5.229	5.367	5.587	6.066	6.561	6.784	7.217	7.217	7.217	7.217	7.217	7.217	7.217	7.217	7.217
	D	0.993	1.740	1.800	1.800	1.800	1.800	2.800	2.800	2.800	2.800	2.800	2.800	2.800	2.800	2.800	3.050	3.200	3.200	3.200	0.918	0.385	0.626	5.067	5.067	5.229	5.367	5.587	6.066	6.561	6.784	7.217
Ecart entre Projet - Terrain		-2.67	0.993	1.740	1.800	1.800	1.800	2.800	2.800	2.800	2.800	2.800	2.800	2.800	2.800	2.800	3.050	3.200	3.200	3.200	0.918	0.385	0.626	5.067	5.067	5.229	5.367	5.587	6.066	6.561	6.784	7.217
BBSG	Z	-7.986	-6.907	-5.200	-5.050	-3.200	-3.000	-2.800	-0.000	0.000	2.800	2.800	2.800	3.050	3.200	4.929	5.046	5.229	5.367	5.587	6.066	6.561	6.784	7.217	7.217	7.217	7.217	7.217	7.217	7.217	7.217	7.217
	D	0.993	1.740	1.800	1.800	1.800	1.800	2.800	2.800	2.800	2.800	2.800	2.800	2.800	2.800	2.800	3.050	3.200	3.200	3.200	0.918	0.385	0.626	5.067	5.067	5.229	5.367	5.587	6.066	6.561	6.784	7.217
GB	Z	-7.986	-6.907	-5.200	-5.050	-3.200	-3.000	-2.800	-0.000	0.000	2.800	2.800	2.800	3.050	3.200	4.929	5.046	5.229	5.367	5.587	6.066	6.561	6.784	7.217	7.217	7.217	7.217	7.217	7.217	7.217	7.217	7.217
	D	0.993	1.740	1.800	1.800	1.800	1.800	2.800	2.800	2.800	2.800	2.800	2.800	2.800	2.800	2.800	3.050	3.200	3.200	3.200	0.918	0.385	0.626	5.067	5.067	5.229	5.367	5.587	6.066	6.561	6.784	7.217
Dalles	Z	-7.986	-6.907	-5.200	-5.050	-3.200	-3.000	-2.800	-0.000	0.000	2.800	2.800	2.800	3.050	3.200	4.929	5.046	5.229	5.367	5.587	6.066	6.561	6.784	7.217	7.217	7.217	7.217	7.217	7.217	7.217	7.217	7.217
	D	0.993	1.740	1.800	1.800	1.800	1.800	2.800	2.800	2.800	2.800	2.800	2.800	2.800	2.800	2.800	3.050	3.200	3.200	3.200	0.918	0.385	0.626	5.067	5.067	5.229	5.367	5.587	6.066	6.561	6.784	7.217
GNT 20	Z	-7.986	-6.907	-5.200	-5.050	-3.200	-3.000	-2.800	-0.000	0.000	2.800	2.800	2.800	3.050	3.200	4.929	5.046	5.229	5.367	5.587	6.066	6.561	6.784	7.217	7.217	7.217	7.217	7.217	7.217	7.217	7.217	7.217
	D	0.993	1.740	1.800	1.800	1.800	1.800	2.800	2.800	2.800	2.800	2.800	2.800	2.800	2.800	2.800	3.050	3.200	3.200	3.200	0.918	0.385	0.626	5.067	5.067	5.229	5.367	5.587	6.066	6.561	6.784	7.217
Fond de forme	Z	-7.986	-6.907	-5.200	-5.050	-3.200	-3.000	-2.800	-0.000	0.000	2.800	2.800	2.800	3.050	3.200	4.929	5.046	5.229	5.367	5.587	6.066	6.561	6.784	7.217	7.217	7.217	7.217	7.217	7.217	7.217	7.217	7.217
	D	0.993	1.740	1.800	1.800	1.800	1.800	2.800	2.800	2.800	2.800	2.800	2.800	2.800	2.800	2.800	3.050	3.200	3.200	3.200	0.918	0.385	0.626	5.067	5.067	5.229	5.367	5.587	6.066	6.561	6.784	7.217

Carnet de profils en travers - RD

Axe : Axe
 N° profil : 44
 Pk : 109.708m

Z Tn : 491.34
 Z Projet : 491.4

Section remblais : 0.0
 Section déblais : 3.17

Echelle X : 1/50
 Echelle Z : 1/50

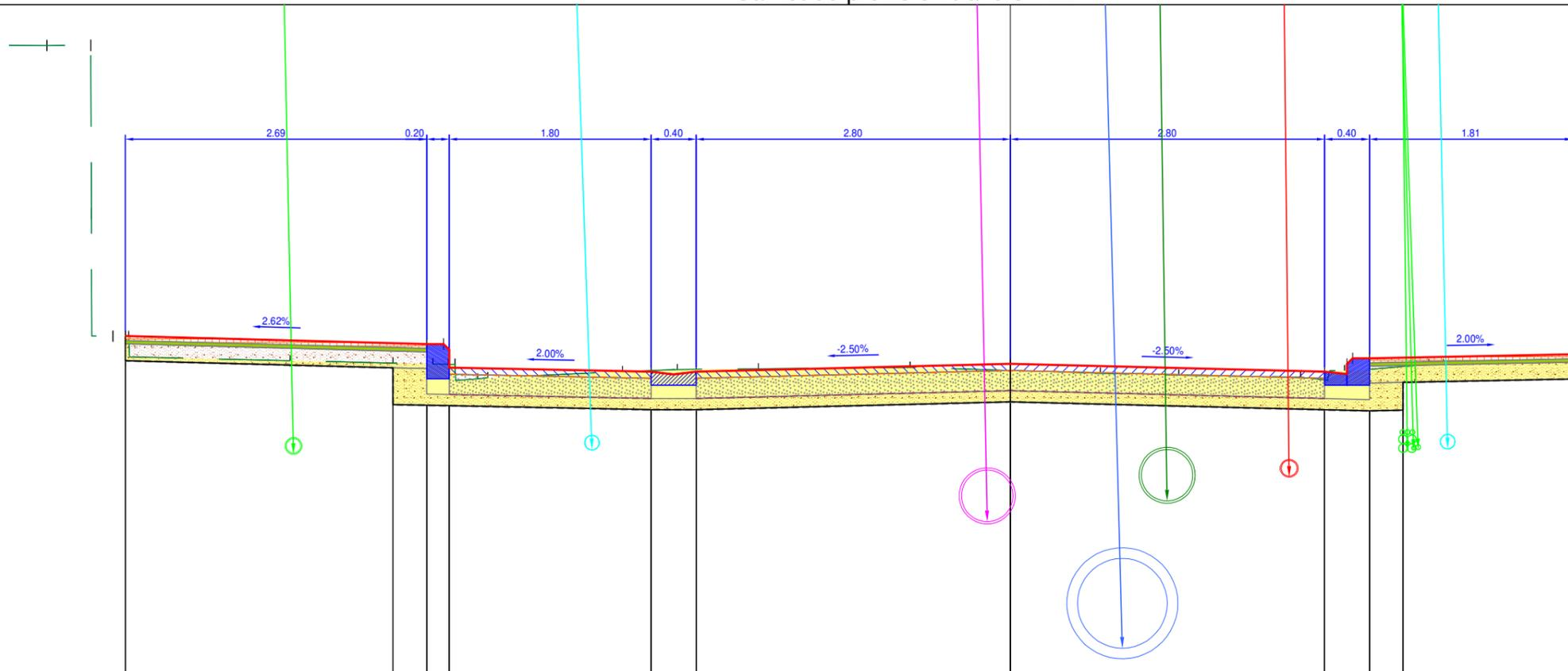

Terrain	Z	494.24	494.24	491.43	491.41	491.40	491.33	491.35	491.36	491.37	491.34	491.32	491.30	491.28	491.26	491.34	491.35	491.38	491.39	491.40	491.46	496.00	496.00	496.00	496.00	496.00	496.00	496.00	
	D	-8.585	-8.194	-6.416	-5.501	-5.145	-3.456	-2.967	-2.244	-0.893	0.000	0.802	0.699	1.502	2.588	2.803	2.979	3.205	3.529	3.730	5.049	5.222	5.382	6.591	6.959	8.053	8.245	8.460	8.683
Projet	Z	491.65	491.65	491.43	491.41	491.40	491.33	491.35	491.36	491.37	491.34	491.32	491.30	491.28	491.26	491.34	491.35	491.38	491.39	491.40	491.49	496.00	496.00	496.00	496.00	496.00	496.00	496.00	
	D	-7.885	-7.885	2.685	2.685	1.800	1.800	1.800	2.800	2.800	0.000	2.800	2.800	2.800	2.800	3.000	3.050	3.200	3.529	3.860	5.010	5.222	5.382	6.591	6.959	8.053	8.245	8.460	8.683
Ecart entre Projet - Terrain		-0.00	-0.00	2.685	2.685	1.800	1.800	2.800	2.800	0.000	2.800	2.800	2.800	2.800	2.800	3.000	3.050	3.200	3.529	3.860	5.010	5.222	5.382	6.591	6.959	8.053	8.245	8.460	8.683
BBSG	Z	491.31	491.31	491.31	491.31	491.33	491.33	491.33	491.33	491.33	491.34	491.32	491.30	491.28	491.26	491.34	491.35	491.38	491.39	491.40	491.49	496.00	496.00	496.00	496.00	496.00	496.00	496.00	
	D	-5.000	-5.000	1.800	1.800	1.800	2.800	2.800	2.800	0.000	2.800	2.800	2.800	2.800	2.800	3.000	3.050	3.200	3.529	3.860	5.010	5.222	5.382	6.591	6.959	8.053	8.245	8.460	8.683
GB	Z	491.31	491.31	491.31	491.31	491.33	491.33	491.33	491.33	491.33	491.34	491.32	491.30	491.28	491.26	491.34	491.35	491.38	491.39	491.40	491.49	496.00	496.00	496.00	496.00	496.00	496.00	496.00	
	D	-5.000	-5.000	1.800	1.800	1.800	2.800	2.800	2.800	0.000	2.800	2.800	2.800	2.800	2.800	3.000	3.050	3.200	3.529	3.860	5.010	5.222	5.382	6.591	6.959	8.053	8.245	8.460	8.683
Dalles	Z	491.65	491.65	491.43	491.41	491.40	491.33	491.35	491.36	491.37	491.34	491.32	491.30	491.28	491.26	491.34	491.35	491.38	491.39	491.40	491.49	496.00	496.00	496.00	496.00	496.00	496.00	496.00	
	D	-7.885	-7.885	2.685	2.685	1.800	1.800	1.800	2.800	2.800	0.000	2.800	2.800	2.800	2.800	3.000	3.050	3.200	3.529	3.860	5.010	5.222	5.382	6.591	6.959	8.053	8.245	8.460	8.683
GNT 20	Z	491.58	491.58	491.43	491.41	491.40	491.33	491.35	491.36	491.37	491.34	491.32	491.30	491.28	491.26	491.34	491.35	491.38	491.39	491.40	491.49	496.00	496.00	496.00	496.00	496.00	496.00	496.00	
	D	-7.885	-7.885	2.385	2.385	1.800	1.800	1.800	2.800	2.800	0.000	2.800	2.800	2.800	2.800	3.000	3.050	3.200	3.529	3.860	5.010	5.222	5.382	6.591	6.959	8.053	8.245	8.460	8.683
Fond de forme	Z	491.65	491.65	491.43	491.41	491.40	491.33	491.35	491.36	491.37	491.34	491.32	491.30	491.28	491.26	491.34	491.35	491.38	491.39	491.40	491.49	496.00	496.00	496.00	496.00	496.00	496.00	496.00	
	D	-7.885	-7.885	2.385	2.385	1.800	1.800	1.800	2.800	2.800	0.000	2.800	2.800	2.800	2.800	3.000	3.050	3.200	3.529	3.860	5.010	5.222	5.382	6.591	6.959	8.053	8.245	8.460	8.683

Carnet de profils en travers - RD

Axe : Axe
 N° profil : 45
 Pk : 113.644m
 Z Tn : 491.45
 Z Projet : 491.52
 Section remblais : 0.0
 Section déblais : 3.62
 Echelle X : 1/50
 Echelle Z : 1/50

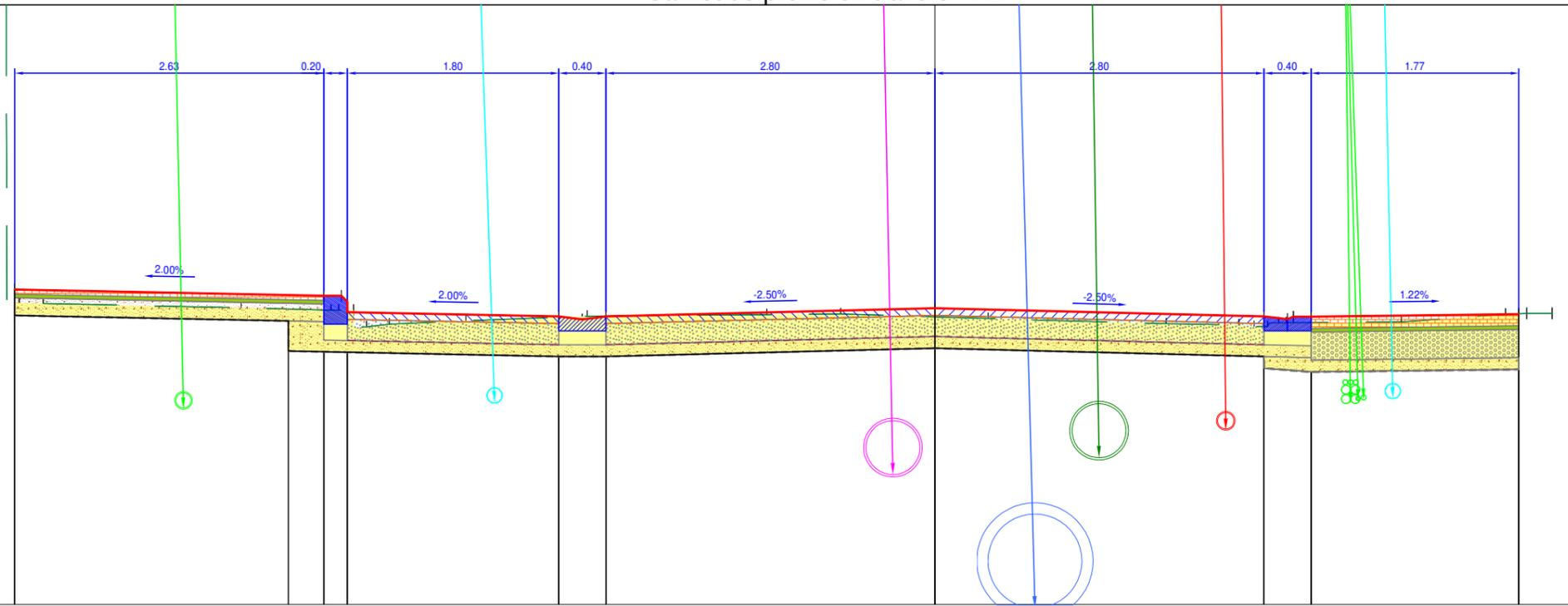

Plan Comp : 489.0

Terrain	Z	-8.021	-7.902	-7.791	-7.588	-5.903	-5.140	-5.074	-4.946	-4.836	-4.640	-3.991	-2.958	-1.430	-0.803	0.000	0.453	1.517	1.970	2.588	2.715	2.830	2.968	3.969	4.855	5.037	5.252	5.408	5.412	7.267	496.00				
	D	1.089				1.686		0.763				0.649		1.034			1.528			0.618				0.980	3.969	4.855	5.037	5.252	5.408	5.412	7.267	496.00			
GC	Z																																		
	D																																		
Projet	Z																																		
	D																																		
Ecart entre Projet - Terrain																																			
BBSG	Z																																		
	D																																		
GB	Z																																		
	D																																		
Dalles	Z																																		
	D																																		
GNT 20	Z																																		
	D																																		
Fond de forme	Z																																		
	D																																		

Carnet de profils en travers - RD

Axe : Axe
 N° profil : 48
 Pk : 120.000m

 Z Tn : 491.61
 Z Projet : 491.72

 Section remblais : 0.0
 Section déblais : 3.06

 Echelle X : 1/50
 Echelle Z : 1/50

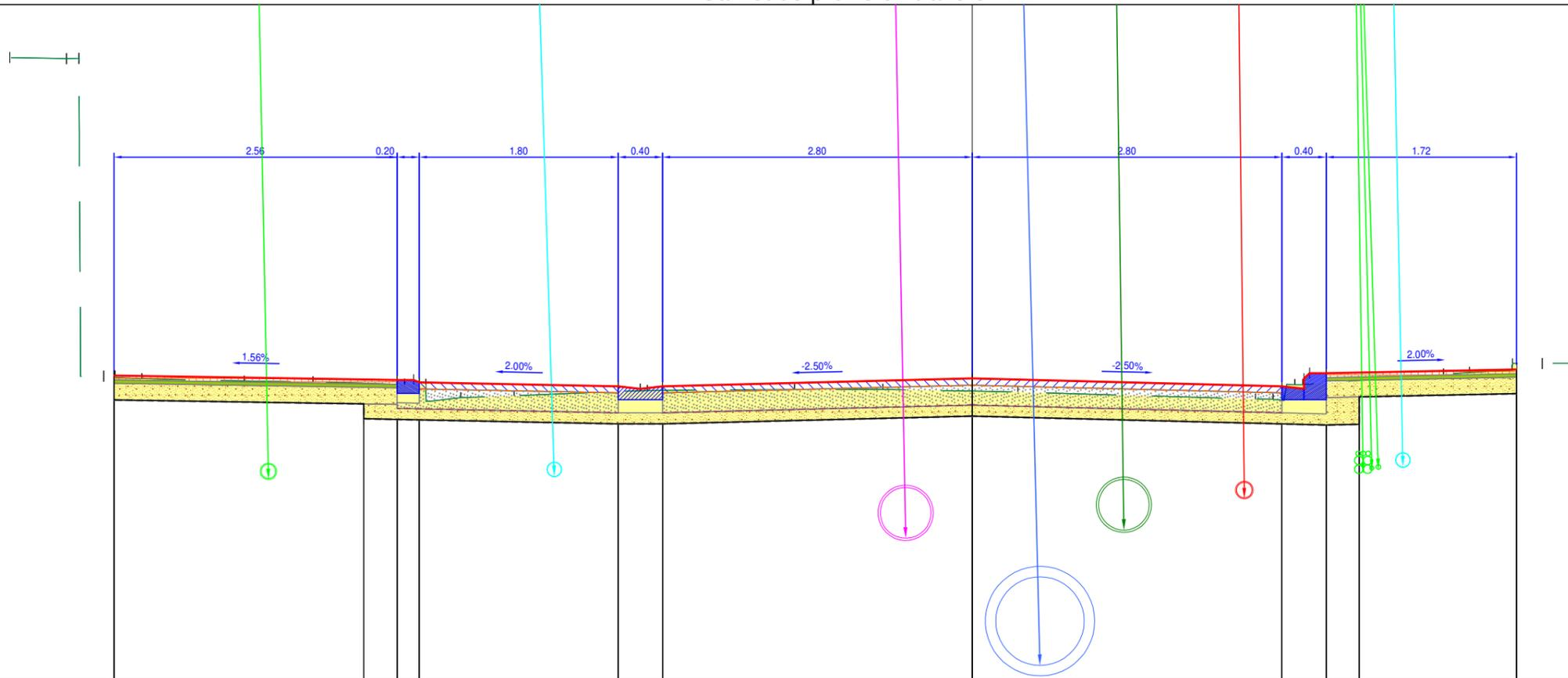

Plan Comp : 489.0

Terrain	Z	494.62	494.61	494.62	491.74	491.72	491.70	491.69	491.67	491.67	491.54	491.55	491.57	491.62	491.63	491.61	491.60	491.54	491.54	491.54	491.67	491.80	491.85	491.86	491.86	491.88	496.00	496.00			
	D	8.701	8.188	8.073	7.748	7.506	6.583	5.961	5.133	5.130	4.940	4.624	4.141	3.200	2.800	2.000	0.413	2.561	2.701	2.667	2.989	4.882	4.885	5.155	5.416	5.431	5.685	5.950			
Projet	Z	491.75	491.75	491.75	491.75	491.75	491.75	491.75	491.75	491.75	491.75	491.75	491.75	491.75	491.75	491.75	491.75	491.75	491.75	491.75	491.75	491.75	491.75	491.75	491.75	491.75	491.75	491.75			
	D	7.760	7.760	7.760	7.760	7.760	2.560	2.560	5.200	5.050	5.000	1.800	1.800	3.200	3.000	2.800	0.000	2.800	2.800	3.000	3.050	3.200	1.273	4.262	4.496	4.882	4.885	5.155	5.416	5.431	5.685
Ecart entre Projet - Terrain		-0.01	-0.01	-0.01	-0.01	-0.01	0.00	0.00	-0.04	-0.02	-0.02	0.00	0.00	-0.04	-0.04	-0.11	0.00	-0.13	-0.09	-0.09	-0.05	-0.05	-0.05	-0.05	-0.05	-0.05	-0.05	-0.05	-0.05	-0.05	-0.05
BBSG	Z	491.63	491.63	491.63	491.63	491.63	491.63	491.63	491.63	491.63	491.63	491.63	491.63	491.63	491.63	491.63	491.63	491.63	491.63	491.63	491.63	491.63	491.63	491.63	491.63	491.63	491.63	491.63	491.63	491.63	491.63
	D	5.000	5.000	5.000	5.000	5.000	1.800	1.800	5.000	5.000	5.000	1.800	1.800	3.200	3.000	2.800	0.000	2.800	2.800	3.000	3.050	3.200	1.273	4.262	4.496	4.882	4.885	5.155	5.416	5.431	5.685
GB	Z	491.59	491.59	491.59	491.59	491.59	491.59	491.59	491.59	491.59	491.59	491.59	491.59	491.59	491.59	491.59	491.59	491.59	491.59	491.59	491.59	491.59	491.59	491.59	491.59	491.59	491.59	491.59	491.59	491.59	491.59
	D	5.000	5.000	5.000	5.000	5.000	1.800	1.800	5.000	5.000	5.000	1.800	1.800	3.200	3.000	2.800	0.000	2.800	2.800	3.000	3.050	3.200	1.273	4.262	4.496	4.882	4.885	5.155	5.416	5.431	5.685
Dalles	Z	491.75	491.75	491.75	491.75	491.75	491.75	491.75	491.75	491.75	491.75	491.75	491.75	491.75	491.75	491.75	491.75	491.75	491.75	491.75	491.75	491.75	491.75	491.75	491.75	491.75	491.75	491.75	491.75	491.75	491.75
	D	7.760	7.760	7.760	7.760	7.760	2.560	2.560	5.200	5.050	5.000	1.800	1.800	3.200	3.000	2.800	0.000	2.800	2.800	3.000	3.050	3.200	1.273	4.262	4.496	4.882	4.885	5.155	5.416	5.431	5.685
GNT 20	Z	491.53	491.53	491.53	491.53	491.53	491.53	491.53	491.53	491.53	491.53	491.53	491.53	491.53	491.53	491.53	491.53	491.53	491.53	491.53	491.53	491.53	491.53	491.53	491.53	491.53	491.53	491.53	491.53	491.53	491.53
	D	7.760	7.760	7.760	7.760	7.760	2.260	2.260	5.500	5.200	5.000	1.800	1.800	3.200	3.000	2.800	0.000	2.800	2.800	3.000	3.050	3.200	1.423	4.262	4.496	4.882	4.885	5.155	5.416	5.431	5.685
Fond de forme	Z	491.75	491.75	491.75	491.75	491.75	491.75	491.75	491.75	491.75	491.75	491.75	491.75	491.75	491.75	491.75	491.75	491.75	491.75	491.75	491.75	491.75	491.75	491.75	491.75	491.75	491.75	491.75	491.75	491.75	491.75
	D	7.760	7.760	7.760	7.760	7.760	2.260	2.260	5.500	5.200	5.000	1.800	1.800	3.200	3.000	2.800	0.000	2.800	2.800	3.000	3.050	3.200	1.423	4.262	4.496	4.882	4.885	5.155	5.416	5.431	5.685

Carnet de profils en travers - RD

Axe : Axe
 N° profil : 58
 Pk : 146.543m

 Z Tn : 492.25
 Z Projet : 492.32

 Section remblais : 0.0
 Section déblais : 3.02

 Echelle X : 1/50
 Echelle Z : 1/50

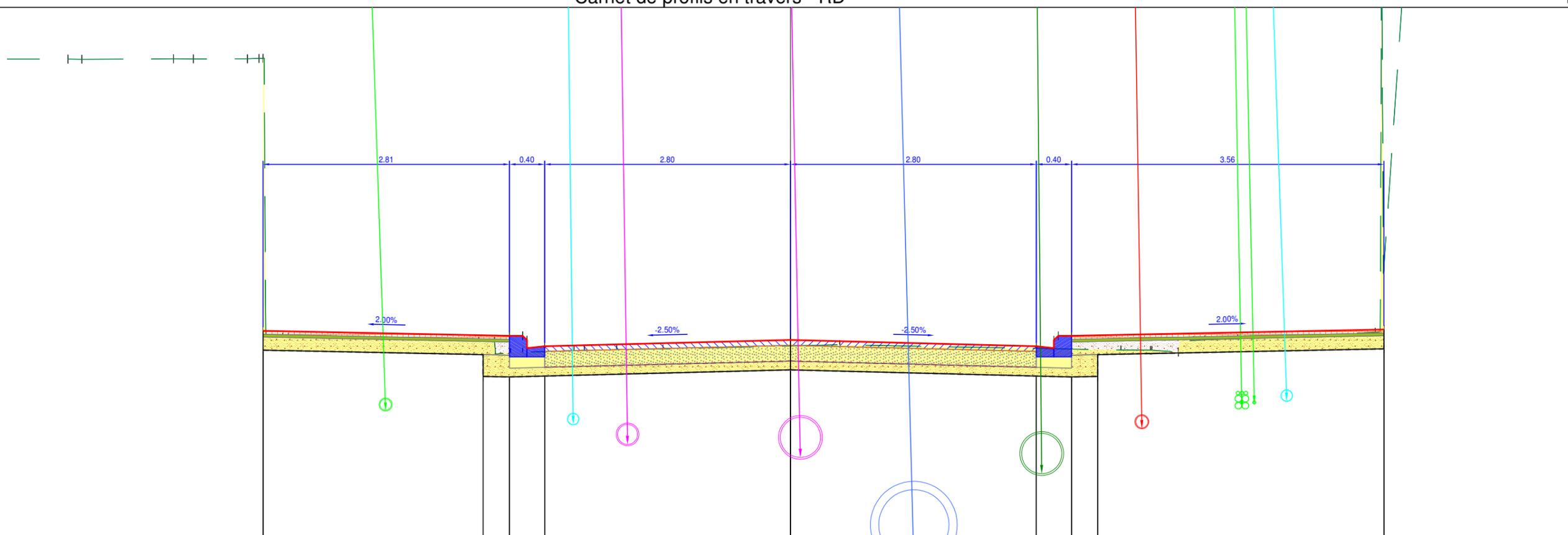

Plan Comp : 490.0

Terrain	Z	-8.230	-8.069	-7.026	-6.800	-6.185	-6.054	-5.782	-3.549	-3.372	-3.186	-3.050	-2.465	-2.347	-1.978	-1.451	0.000	0.561	0.561	3.202	3.763	4.100	4.118	4.417	4.589	4.718	5.094	6.660	6.759	7.062	8.772	497.00						
	D	1.806	1.043	0.615	0.615	0.615	0.615	0.615	2.169	3.549	3.372	3.186	3.050	2.465	2.347	1.978	1.451	0.000	0.561	0.561	3.202	3.763	4.100	4.118	4.417	4.589	4.718	5.094	6.660	6.759	7.062	8.772	497.00					
Projet	Z					-492.42	-492.42	-492.35	-492.31	-492.31	-492.17	-492.18	-492.20	-492.20	-492.21	-492.21	-492.25	-492.26	-492.26	-492.25	-492.25	-492.25	-492.25	-492.25	-492.18	-492.31	-492.32	-492.33	-492.40	-492.43	-492.43	-492.43	-492.43	-492.43	497.00			
	D					6.007	6.007	6.007	6.007	6.007	6.007	6.007	6.007	6.007	6.007	6.007	6.007	6.007	6.007	6.007	6.007	6.007	6.007	6.007	6.007	6.007	6.007	6.007	6.007	6.007	6.007	6.007	6.007	6.007	6.007	6.007		
Ecart entre Projet - Terrain						-3.10	-3.10	-3.10	-3.10	-3.10	-3.10	-3.10	-3.10	-3.10	-3.10	-3.10	-3.10	-3.10	-3.10	-3.10	-3.10	-3.10	-3.10	-3.10	-3.10	-3.10	-3.10	-3.10	-3.10	-3.10	-3.10	-3.10	-3.10	-3.10	-3.10	-3.10		
BBSG	Z					492.19	492.19	492.19	492.19	492.19	492.19	492.19	492.19	492.19	492.19	492.19	492.19	492.19	492.19	492.19	492.19	492.19	492.19	492.19	492.19	492.19	492.19	492.19	492.19	492.19	492.19	492.19	492.19	492.19	492.19	492.19		
	D					2.800	2.800	2.800	2.800	2.800	2.800	2.800	2.800	2.800	2.800	2.800	2.800	2.800	2.800	2.800	2.800	2.800	2.800	2.800	2.800	2.800	2.800	2.800	2.800	2.800	2.800	2.800	2.800	2.800	2.800	2.800	2.800	
GB	Z					492.01	492.01	492.01	492.01	492.01	492.01	492.01	492.01	492.01	492.01	492.01	492.01	492.01	492.01	492.01	492.01	492.01	492.01	492.01	492.01	492.01	492.01	492.01	492.01	492.01	492.01	492.01	492.01	492.01	492.01	492.01	492.01	
	D					2.800	2.800	2.800	2.800	2.800	2.800	2.800	2.800	2.800	2.800	2.800	2.800	2.800	2.800	2.800	2.800	2.800	2.800	2.800	2.800	2.800	2.800	2.800	2.800	2.800	2.800	2.800	2.800	2.800	2.800	2.800	2.800	2.800
Dalles	Z					492.38	492.38	492.38	492.38	492.38	492.38	492.38	492.38	492.38	492.38	492.38	492.38	492.38	492.38	492.38	492.38	492.38	492.38	492.38	492.38	492.38	492.38	492.38	492.38	492.38	492.38	492.38	492.38	492.38	492.38	492.38	492.38	
	D					6.007	6.007	6.007	6.007	6.007	6.007	6.007	6.007	6.007	6.007	6.007	6.007	6.007	6.007	6.007	6.007	6.007	6.007	6.007	6.007	6.007	6.007	6.007	6.007	6.007	6.007	6.007	6.007	6.007	6.007	6.007	6.007	6.007
GNT 20	Z					492.20	492.20	492.20	492.20	492.20	492.20	492.20	492.20	492.20	492.20	492.20	492.20	492.20	492.20	492.20	492.20	492.20	492.20	492.20	492.20	492.20	492.20	492.20	492.20	492.20	492.20	492.20	492.20	492.20	492.20	492.20	492.20	492.20
	D					6.007	6.007	6.007	6.007	6.007	6.007	6.007	6.007	6.007	6.007	6.007	6.007	6.007	6.007	6.007	6.007	6.007	6.007	6.007	6.007	6.007	6.007	6.007	6.007	6.007	6.007	6.007	6.007	6.007	6.007	6.007	6.007	6.007
Fond de forme	Z					492.26	492.26	492.26	492.26	492.26	492.26	492.26	492.26	492.26	492.26	492.26	492.26	492.26	492.26	492.26	492.26	492.26	492.26	492.26	492.26	492.26	492.26	492.26	492.26	492.26	492.26	492.26	492.26	492.26	492.26	492.26	492.26	492.26
	D					6.007	6.007	6.007	6.007	6.007	6.007	6.007	6.007	6.007	6.007	6.007	6.007	6.007	6.007	6.007	6.007	6.007	6.007	6.007	6.007	6.007	6.007	6.007	6.007	6.007	6.007	6.007	6.007	6.007	6.007	6.007	6.007	6.007

Carnet de profils en travers - RD

Axe : Axe
 N° profil : 59
 Pk : 149.175m

 Z Tn : 492.32
 Z Projet : 492.38

 Section remblais : 0.0
 Section déblais : 4.09

 Echelle X : 1/50
 Echelle Z : 1/50

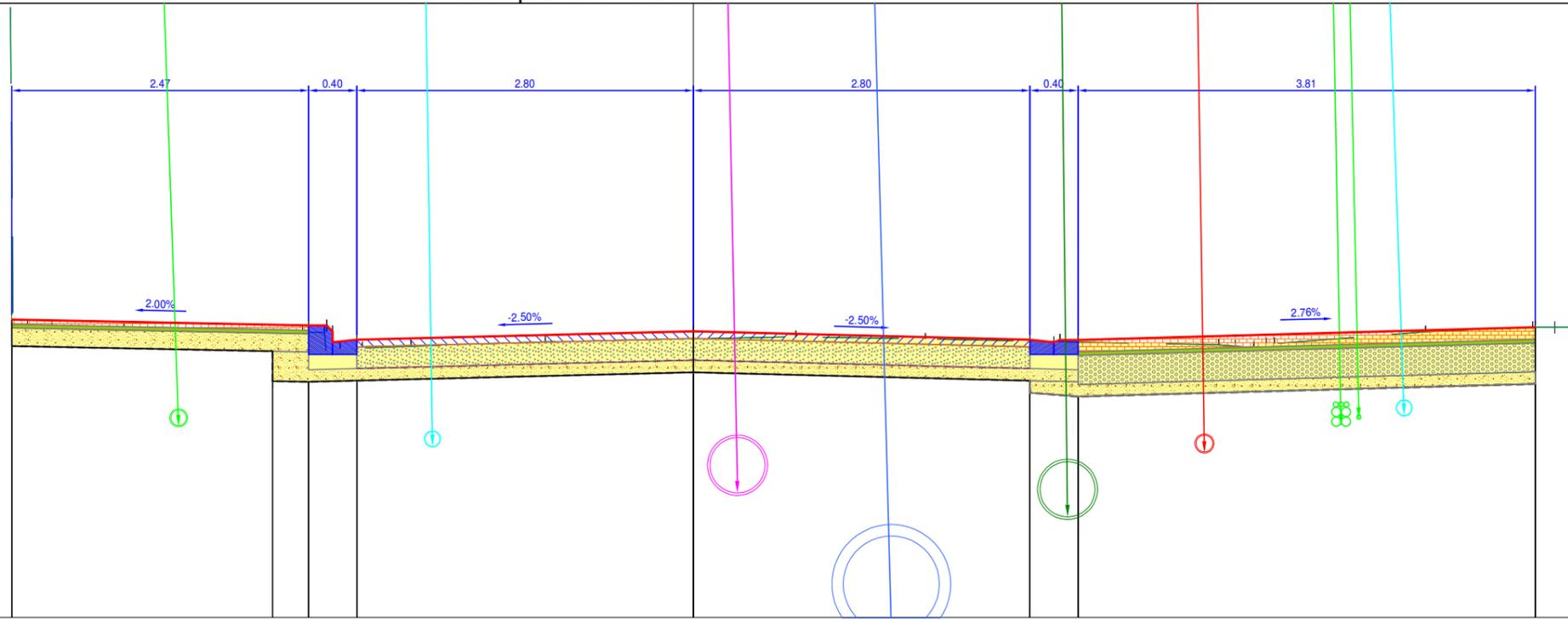

Plan Comp : 490.0

	Terrain		GC		Projet		Ecart entre Projet - Terrain		BBSG		GB		Dalles		GNT 20		Fond de forme		
	Z	D	Z	D	Z	D			Z	D	Z	D	Z	D	Z	D	Z	D	
	-8.538	-8.411																	
	-495.62	-495.62																	
		0.825																	
	-7.586	-7.407																	
	-495.62	-495.62																	
		1.284																	
	-6.123	-6.005																	
	-495.62	-495.62																	
		5.745																	
	-5.745	-5.669																	
	-495.62	-492.41																	
		0.598																	
	-4.738	-4.738																	
	-492.40	-492.40																	
		1.487																	
	-3.251	-3.069																	
	-492.37	-492.37																	
		3.069																	
	-3.069	-2.998																	
	-492.37	-492.23																	
		2.998																	
	-2.753	-2.753																	
	-492.24	-492.24																	
		0.404																	
	-2.350	-2.350																	
	-492.25	-492.25																	
		1.119																	
	-1.231	-1.231																	
	-492.29	-492.29																	
		1.231																	
	0.000	0.000																	
	-492.32	-492.32																	
		0.853																	
	0.853	0.853																	
	-492.33	-492.33																	
		1.078																	
	1.931	1.931																	
	-492.31	-492.31																	
		2.440																	
	2.440	2.440																	
	-492.31	-492.31																	
		3.805																	
	4.371	4.510																	
	-492.26	-492.25																	
		4.664																	
	-492.25	-492.24																	
		4.767																	
	-492.28	-492.28																	
		4.835																	
	1.258	1.258																	
	6.093	6.093																	
	-492.37	-492.37																	
		0.890																	
	6.983	7.168																	
	-492.41	-492.41																	
		7.358																	
	-492.41	-497.00																	
		0.897																	
	8.253	8.253																	
	-497.00	-497.00																	

Carnet de profils en travers - RD

Axe : Axe
 N° profil : 62
 Pk : 159.146m

Z Tn : 492.55
 Z Projet : 492.64

Section remblais : 0.0
 Section déblais : 3.12

Echelle X : 1/50
 Echelle Z : 1/50

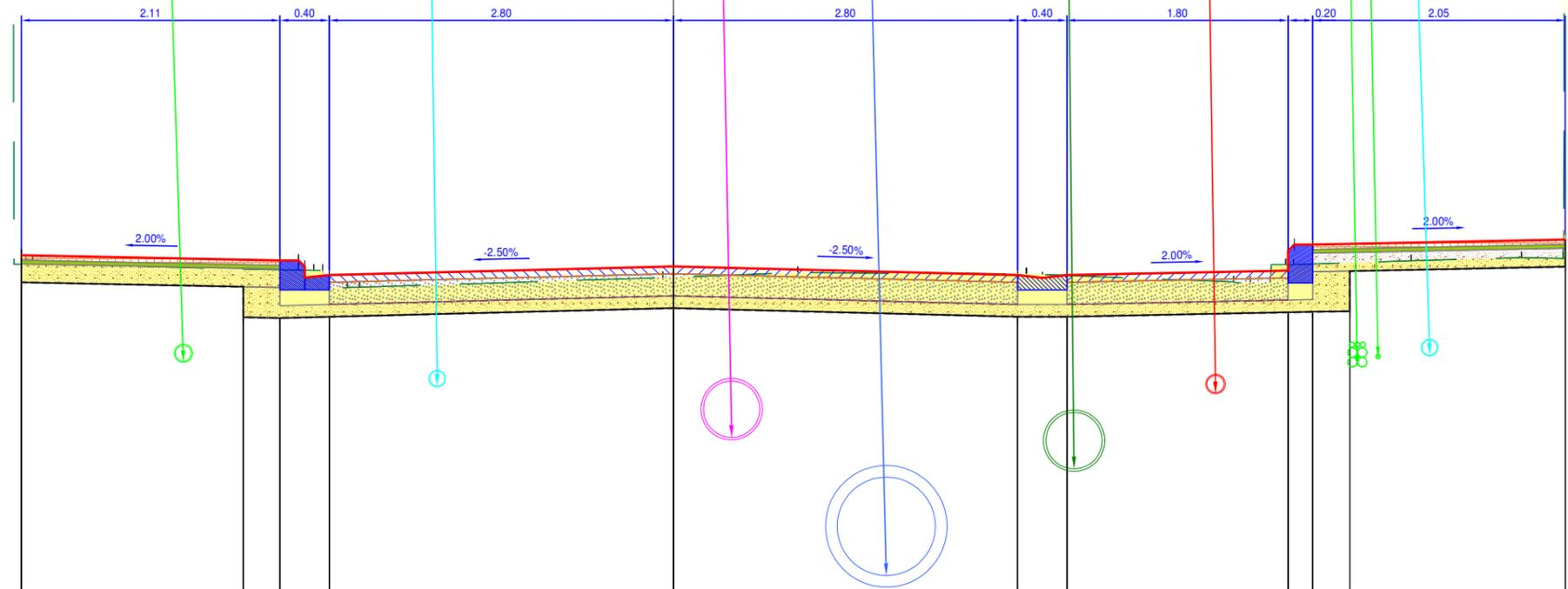

Plan Comp : 490.0

Terrain	Z	-8.012		-5.370	-5.266	-5.213		-3.853		-3.051	-2.862	-2.653		-0.087		1.011		2.869	4.558	4.693	4.855	4.962		6.002	6.899	7.232	7.500	8.529					
	D		2.642				1.361		0.801				2.464		0.000		1.011		2.872			5.045		0.957	6.002	0.897	0.338	7.500	8.529				
Projet	Z			-492.73						-492.69	-492.69	-492.64		-492.64		-492.59		-492.57			-492.50	-492.65		-492.69	-492.71	-492.71	-492.68	-497.00					
	D			-5.304			2.105			-3.199	-3.049	-2.969	-2.799		0.000		2.801		2.801	3.001	3.201		5.001	5.201		2.053		7.254	8.529				
Ecart entre Projet - Terrain				-0.07						-0.08	-0.11			-0.09				-0.01				-0.05	-0.16				-4.14						
BBSG	Z																																
	D																																
GB	Z																																
	D																																
Dalles	Z																																
	D																																
GNT 20	Z																																
	D																																
Fond de forme	Z																																
	D																																

Carnet de profils en travers - RD

Axe : Axe
 N° profil : 67
 Pk : 175.005m

Z Tn : 492.96
 Z Projet : 493.11

Section remblais : 0.0
 Section déblais : 2.59

Echelle X : 1/50
 Echelle Z : 1/50

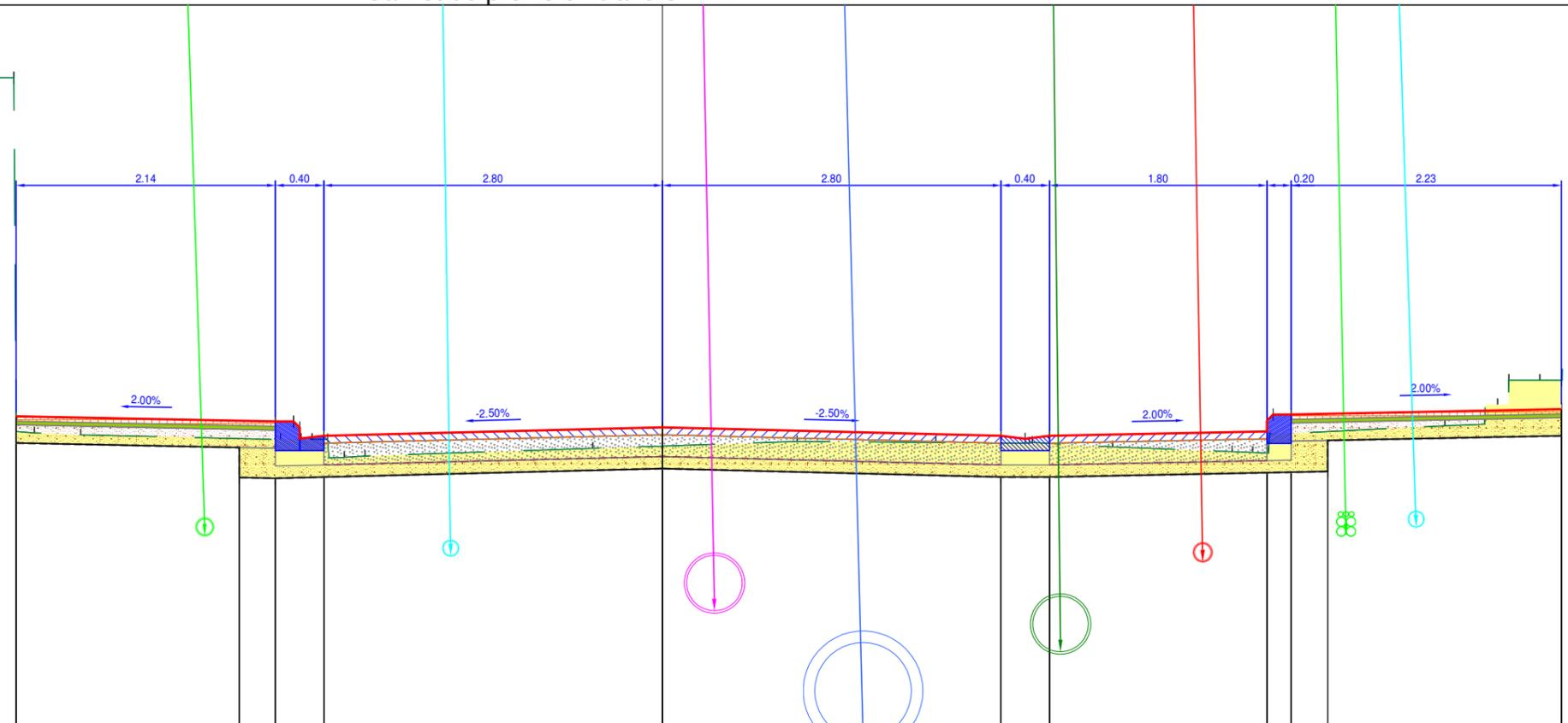

Plan Comp : 490.5

	Terrain		Projet		Ecart entre Projet - Terrain	BBSG		GB		Dalles		GNT 20		Fond de forme	
	Z	D	Z	D		Z	D	Z	D	Z	D	Z	D	Z	D
		4.078													
	-5.363	-5.193	-5.344	-5.344	-0.16										
	-4.811	-4.811													
	1.654		2.145		2.145										
	-3.157	-2.988	-3.199	-3.049	-0.15										
	-4.831	-2.767	-3.199	-2.988	-0.03										
	-2.630	-2.460	-2.799	-2.799											
	1.885		2.799		2.799										
	-0.575	0.000			-0.15										
	1.115	1.115													
	1.146	1.146													
	2.261	0.772	2.801	2.801											
	3.033	3.080	3.001	3.001	-0.06										
	0.663	0.663	3.201	3.201											
	3.723	0.989			1.800										
	4.712	4.882	5.001	5.012	-0.18										
	5.012	5.017	5.001	5.001	-0.15										
	5.204	5.204	5.201	5.201											
	1.268														
	6.472	6.801	7.434	7.434	-0.24										
	7.434	7.598	7.434	7.434											
	7.744	7.744	7.434	7.434											
	8.021	8.021	7.434	7.434											
	0.819	0.819													

Carnet de profils en travers - RD

Axe : Axe
 N° profil : 69
 Pk : 178.540m

Z Tn : 493.05
 Z Projet : 493.17

Section remblais : 0.0
 Section déblais : 2.92

Echelle X : 1/50
 Echelle Z : 1/50

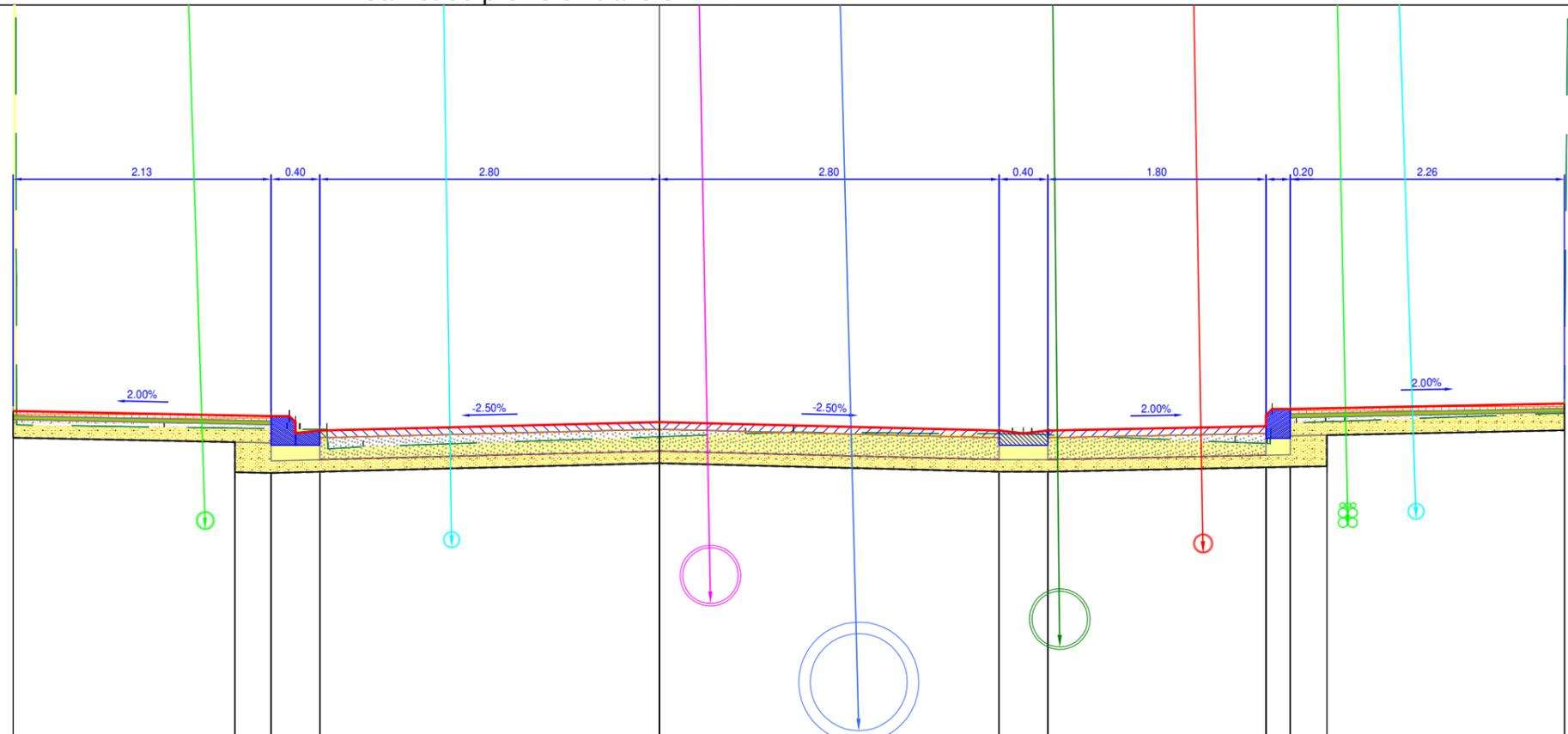

Plan Comp : 490.5

		Terrain		Projet		Ecart entre Projet - Terrain	BBSG		GB		Dalles		GNT 20		Fond de forme	
		Z	D	Z	D		Z	D	Z	D	Z	D	Z	D	Z	D
		497.00	-8.658	493.26	-5.328	-3.74	493.13	2.801	492.86	2.801	493.22	493.04	492.76	2.801	492.76	493.10
	1.292	497.00	-7.366	493.26	-5.328	-3.74	493.13	2.801	492.86	2.801	493.22	493.04	492.76	2.801	492.76	493.10
	1.724	497.00	-5.642	493.26	-5.328	-3.74	493.13	2.801	492.86	2.801	493.22	493.04	492.76	2.801	492.76	493.10
	2.122	497.00	-4.083	493.26	-5.328	-3.74	493.13	2.801	492.86	2.801	493.22	493.04	492.76	2.801	492.76	493.10
	2.441	497.00	-3.068	493.26	-5.328	-3.74	493.13	2.801	492.86	2.801	493.22	493.04	492.76	2.801	492.76	493.10
	2.799	497.00	-2.967	493.26	-5.328	-3.74	493.13	2.801	492.86	2.801	493.22	493.04	492.76	2.801	492.76	493.10
	3.199	497.00	-2.963	493.26	-5.328	-3.74	493.13	2.801	492.86	2.801	493.22	493.04	492.76	2.801	492.76	493.10
	3.395	497.00	-2.741	493.26	-5.328	-3.74	493.13	2.801	492.86	2.801	493.22	493.04	492.76	2.801	492.76	493.10
	3.995	497.00	-2.732	493.26	-5.328	-3.74	493.13	2.801	492.86	2.801	493.22	493.04	492.76	2.801	492.76	493.10
	4.747	497.00	-2.441	493.26	-5.328	-3.74	493.13	2.801	492.86	2.801	493.22	493.04	492.76	2.801	492.76	493.10
	5.001	497.00	-3.199	493.26	-5.328	-3.74	493.13	2.801	492.86	2.801	493.22	493.04	492.76	2.801	492.76	493.10
	5.035	497.00	-3.049	493.26	-5.328	-3.74	493.13	2.801	492.86	2.801	493.22	493.04	492.76	2.801	492.76	493.10
	5.249	497.00	-2.968	493.26	-5.328	-3.74	493.13	2.801	492.86	2.801	493.22	493.04	492.76	2.801	492.76	493.10
	5.492	497.00	-2.799	493.26	-5.328	-3.74	493.13	2.801	492.86	2.801	493.22	493.04	492.76	2.801	492.76	493.10
	5.649	497.00	-2.799	493.26	-5.328	-3.74	493.13	2.801	492.86	2.801	493.22	493.04	492.76	2.801	492.76	493.10
	7.285	497.00	-2.441	493.26	-5.328	-3.74	493.13	2.801	492.86	2.801	493.22	493.04	492.76	2.801	492.76	493.10
	7.458	497.00	-3.199	493.26	-5.328	-3.74	493.13	2.801	492.86	2.801	493.22	493.04	492.76	2.801	492.76	493.10
	7.559	497.00	-3.049	493.26	-5.328	-3.74	493.13	2.801	492.86	2.801	493.22	493.04	492.76	2.801	492.76	493.10
	7.773	497.00	-2.968	493.26	-5.328	-3.74	493.13	2.801	492.86	2.801	493.22	493.04	492.76	2.801	492.76	493.10
	1.836	497.00	-2.799	493.26	-5.328	-3.74	493.13	2.801	492.86	2.801	493.22	493.04	492.76	2.801	492.76	493.10

Carnet de profils en travers - RD

Axe : Axe
 N° profil : 72
 Pk : 188.548m

Z Tn : 493.27
 Z Projet : 493.31

Section remblais : 0.0
 Section déblais : 3.8

Echelle X : 1/50
 Echelle Z : 1/50

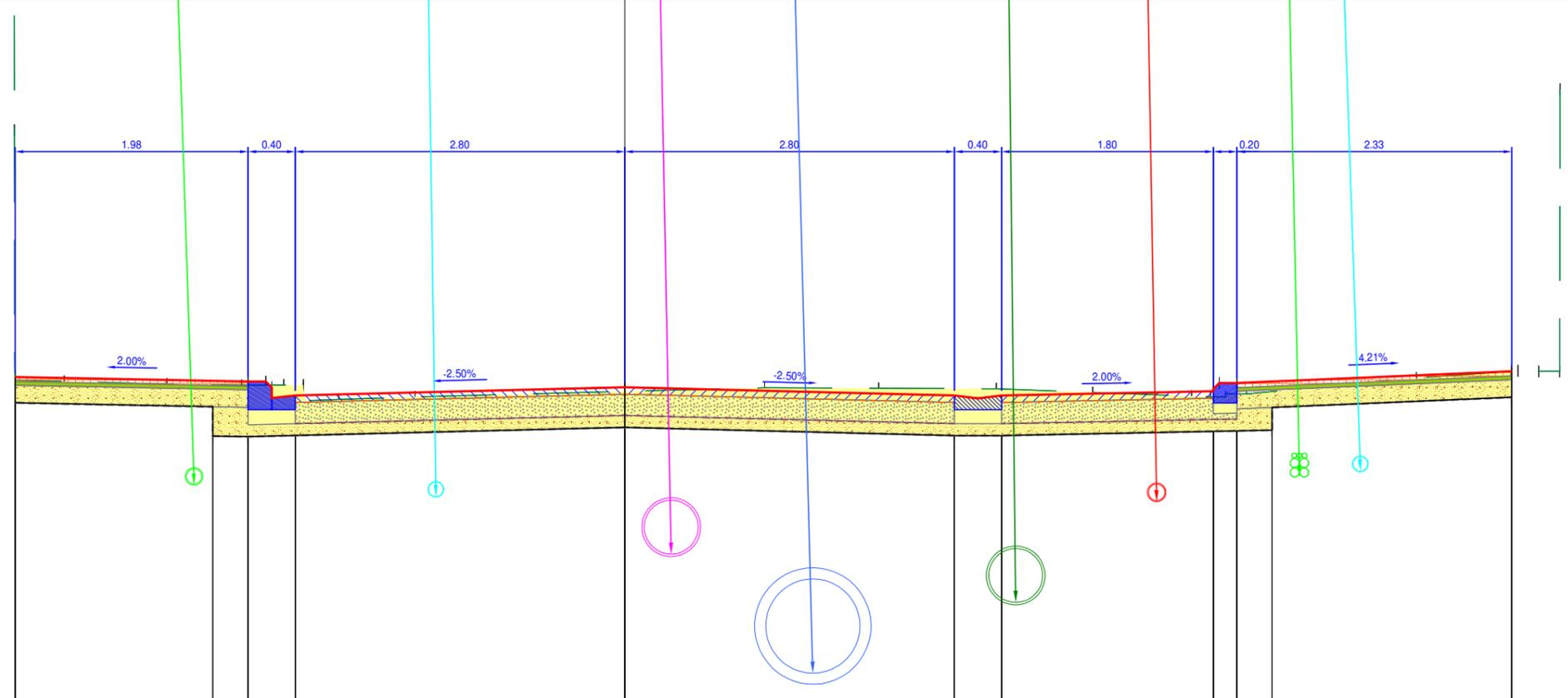

Plan Comp : 490.5

Terrain	Z	-6.265	-5.481	-5.295	-5.184	-4.762	-3.889	-3.255	-2.896	-2.729	-2.429	-1.781	0.000	1.189	1.189	0.970	2.158	0.998	3.156	0.819	3.976	4.816	4.977	5.104	5.281	1.445	6.726	7.535	7.589	7.765	7.942	8.210		
	D	4.139	0.784	0.422	0.422	0.873	0.634	0.358	0.358	0.358	0.648	1.781	0.000	1.189	1.189	0.970	2.158	0.998	3.156	0.819	3.976	4.816	4.977	5.104	5.281	1.445	6.726	7.535	7.589	7.765	7.942	8.210		
Projet	Z																																	
	D																																	
Ecart entre Projet - Terrain																																		
BBSG	Z																																	
	D																																	
GB	Z																																	
	D																																	
Dalles	Z																																	
	D																																	
GNT 20	Z																																	
	D																																	
Fond de forme	Z																																	
	D																																	

Carnet de profils en travers - RD

Axe : Axe
 N° profil : 74
 Pk : 193.744m

Z Tn : 493.37
 Z Projet : 493.44

Section remblais : 0.0
 Section déblais : 3.74

Echelle X : 1/50
 Echelle Z : 1/50

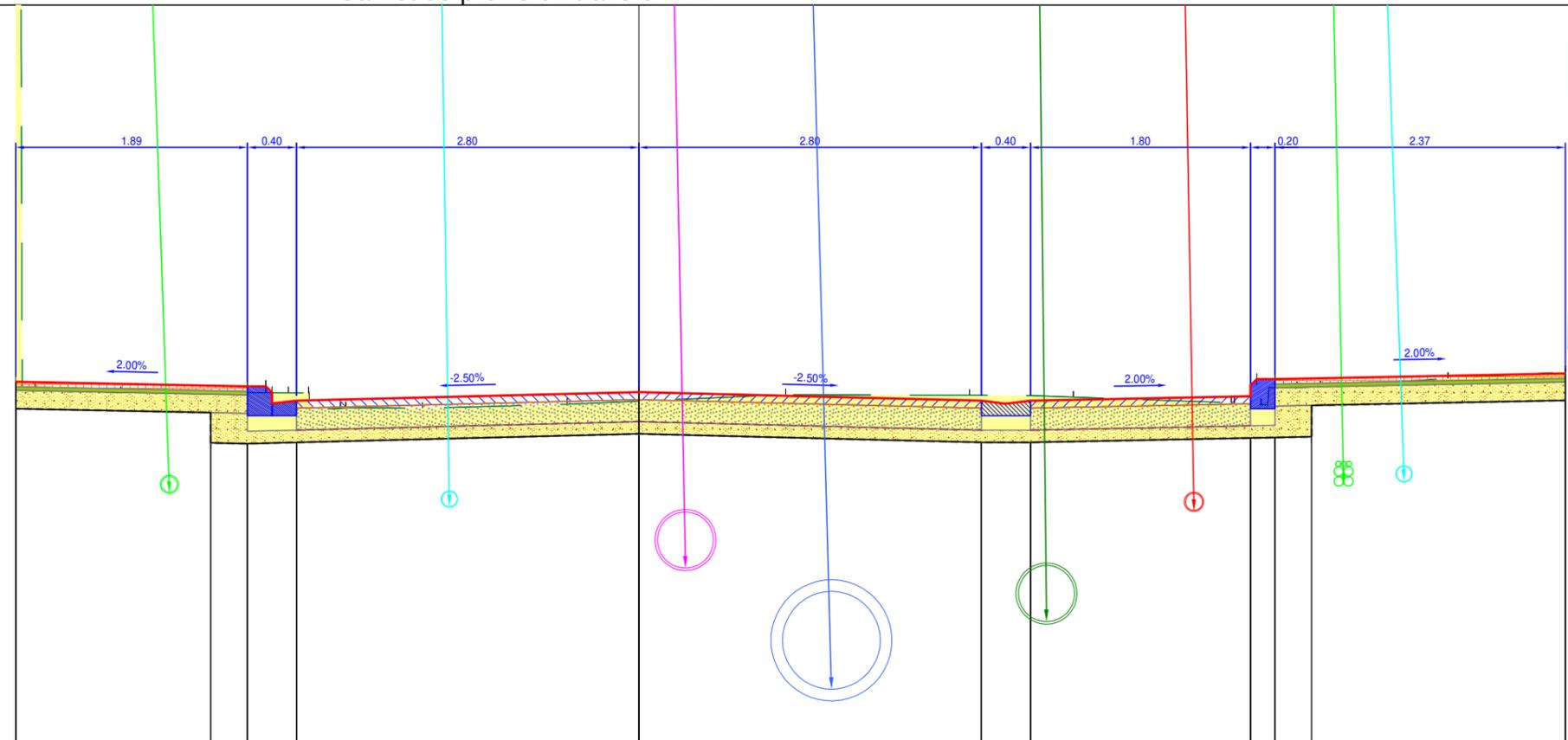

Plan Comp : 490.5

Terrain	Z	497.00	497.00	497.00	493.43	493.43	493.31	493.34	493.37	493.42	493.41	493.41	493.40	493.35	493.35	493.34	493.48	493.55	493.60	498.00
	D	4.012	0.317	0.650	0.700	1.370	0.626	1.183	0.585	0.000	1.201	1.502	2.703	3.198	3.553	1.291	4.844	6.615	7.574	7.934
Projet	Z	493.44	493.44	493.44	493.44	493.44	493.44	493.44	493.44	493.44	493.44	493.44	493.44	493.44	493.44	493.44	493.44	493.44	493.44	493.44
	D	0.000	0.000	0.000	0.000	0.000	0.000	0.000	0.000	0.000	0.000	0.000	0.000	0.000	0.000	0.000	0.000	0.000	0.000	0.000
Ecart entre Projet - Terrain																				
BBSG	Z	493.31	493.31	493.31	493.31	493.31	493.31	493.31	493.31	493.31	493.31	493.31	493.31	493.31	493.31	493.31	493.31	493.31	493.31	493.31
	D	2.800	2.800	2.800	2.800	2.800	2.800	2.800	2.800	2.800	2.800	2.800	2.800	2.800	2.800	2.800	2.800	2.800	2.800	2.800
GB	Z	493.31	493.31	493.31	493.31	493.31	493.31	493.31	493.31	493.31	493.31	493.31	493.31	493.31	493.31	493.31	493.31	493.31	493.31	493.31
	D	2.800	2.800	2.800	2.800	2.800	2.800	2.800	2.800	2.800	2.800	2.800	2.800	2.800	2.800	2.800	2.800	2.800	2.800	2.800
Dalles	Z	493.52	493.52	493.52	493.52	493.52	493.52	493.52	493.52	493.52	493.52	493.52	493.52	493.52	493.52	493.52	493.52	493.52	493.52	493.52
	D	5.094	1.894	3.200	3.200	8.400	5.200	2.374	7.574											
GNT 20	Z	493.30	493.30	493.30	493.30	493.30	493.30	493.30	493.30	493.30	493.30	493.30	493.30	493.30	493.30	493.30	493.30	493.30	493.30	493.30
	D	5.094	1.594	3.500	3.200	2.800	2.800	2.800	2.800	2.800	2.800	2.800	2.800	2.800	2.800	2.800	2.800	2.800	2.800	2.800
Fond de forme	Z	493.30	493.30	493.30	493.30	493.30	493.30	493.30	493.30	493.30	493.30	493.30	493.30	493.30	493.30	493.30	493.30	493.30	493.30	493.30
	D	5.094	1.594	3.500	3.200	2.800	2.800	2.800	2.800	2.800	2.800	2.800	2.800	2.800	2.800	2.800	2.800	2.800	2.800	2.800

Carnet de profils en travers - RD

Axe : Axe
 N° profil : 84
 Pk : 219.438m

Z Tn : 494.02
 Z Projet : 494.11

Section remblais : 0.0
 Section déblais : 4.38

Echelle X : 1/50
 Echelle Z : 1/50

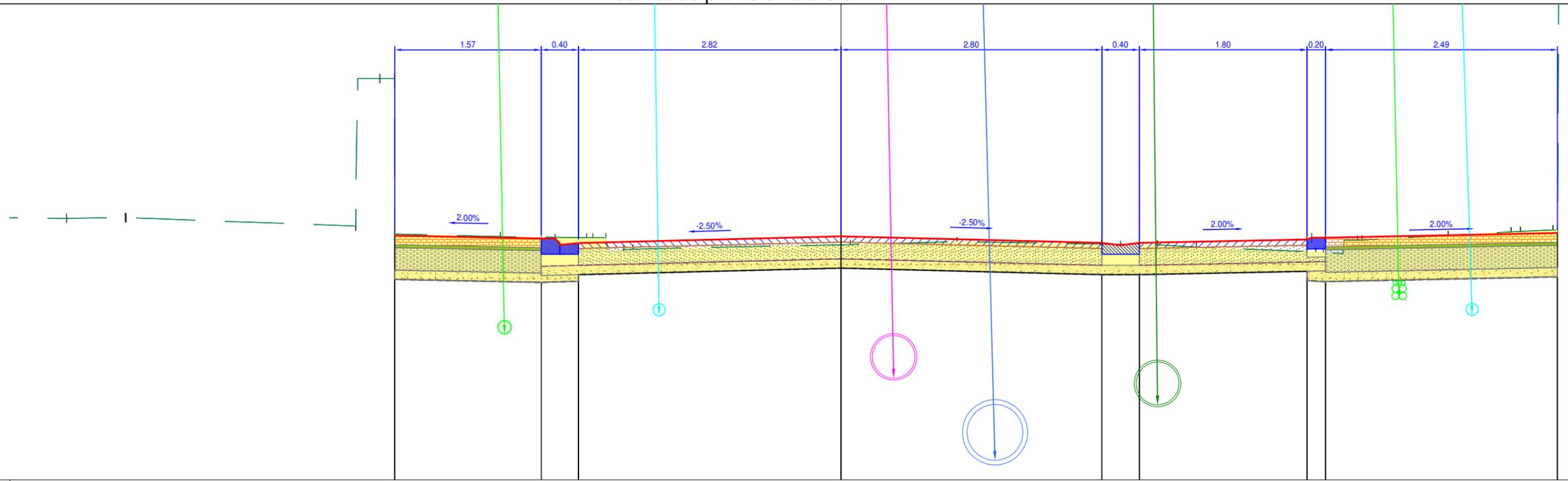

Plan Comp : 491.5

Terrain	Z	494.30	484.31	484.22	494.11	484.09	494.02	494.03	494.02	494.00	494.07	494.12	494.16	494.18	498.00
	D	-8.309	-7.877	-5.205	-3.654	-2.728	0.000	1.246	2.797	3.394	3.815	5.095	6.515	7.191	7.640
GC	Z			483.75	483.96						483.94			484.18	
	D	0.629	2.465	-4.787	-3.217			8.417			5.200	2.489		7.689	
Projet	Z			494.12	494.09	494.04	494.11	494.04	494.04	494.08	494.10	494.14			
	D			-4.787	-3.067	-2.817	0.000	2.800	3.000	3.200	5.000	2.489		7.689	
Ecart entre Projet - Terrain			-0.02	-0.01	-0.06	-0.09			-0.01		-0.13			-0.03	
BBSG	Z			483.98	484.04		494.11	494.04	494.04	494.08	494.10	494.14			
	D			-2.817	-2.817		0.000	2.800	3.200	5.000	5.200	2.489		7.689	
GB	Z			483.80	483.98		494.05	494.04	494.04	483.89	483.89	494.14			
	D			-2.817	-2.817		0.000	2.800	3.200	5.000	5.200	2.489		7.689	
Dalles	Z			494.02	494.09		494.11	494.04	494.04	494.08	494.10	494.14			
	D			-4.787	-3.217		0.000	8.417		5.200	2.489		7.689		
GNT 20	Z			483.65	483.72	483.80	483.87	483.80	483.80	483.94	483.94	483.67			
	D			-4.787	-3.217	-2.817	0.000	2.800	3.200	5.000	5.200	2.489		7.689	
Fond de forme	Z			494.12	493.62	493.70	493.77	493.70	493.70	493.74	493.63	493.67			
	D			-4.787	-3.217	-2.817	0.000	2.800	3.200	5.000	5.200	2.489		7.689	

Carnet de profils en travers - RD

Axe : Axe
 N° profil : 87
 Pk : 229.101m

Z Tn : 494.26
 Z Projet : 494.35

Section remblais : 0.0
 Section déblais : 4.49

Echelle X : 1/50
 Echelle Z : 1/50

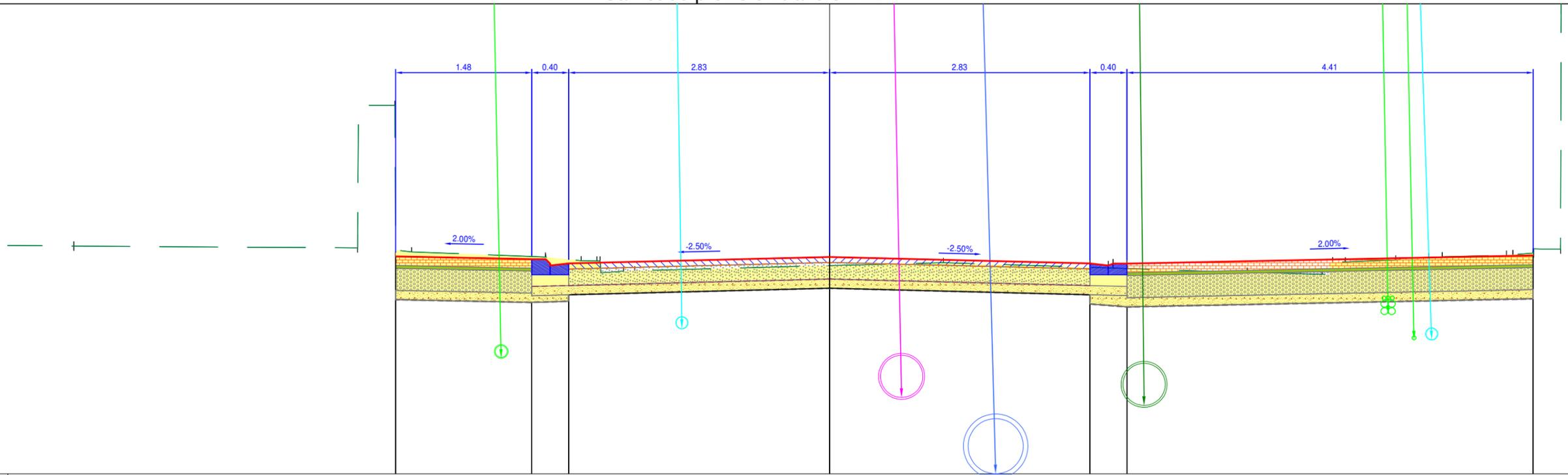

Plan Comp : 492.0

Terrain	Z	-8.202	3.080	-5.121	-4.718	-3.084	-2.696	-2.524	-2.236	-2.113	0.000	1.236	1.236	3.297	4.533	5.113	5.345	5.460	5.597	6.144	6.502	6.648	7.345	7.635	7.833	8.366	
	D	-494.47		494.45	496.00	494.35	494.31	494.31	494.20		494.26	494.29		494.29	494.19	494.17	494.17	494.30	494.30	494.32	494.34	494.36	494.36	494.40	494.44	498.00	
GC	Z			493.99	494.23	494.20																					
	D			494.23	494.23	494.20																					
Projet	Z			494.36		494.33	494.33	494.28			494.35			494.28	494.28	494.28	494.28	494.28	494.28	494.28	494.28	494.28	494.28	494.28	494.28	494.28	
	D			494.36		494.33	494.33	494.28			494.35			494.28	494.28	494.28	494.28	494.28	494.28	494.28	494.28	494.28	494.28	494.28	494.28	494.28	
Ecart entre Projet - Terrain				-0.07		-0.03	-0.04			-0.09			-0.04	-0.05										-0.03			
BBSG	Z			494.22	494.22	494.22	494.22	494.22			494.35			494.22	494.22	494.22	494.22	494.22	494.22	494.22	494.22	494.22	494.22	494.22	494.22	494.22	
	D			494.22	494.22	494.22	494.22	494.22			494.35			494.22	494.22	494.22	494.22	494.22	494.22	494.22	494.22	494.22	494.22	494.22	494.22	494.22	
GB	Z			494.04	494.04	494.04	494.04	494.04			494.29			494.04	494.04	494.04	494.04	494.04	494.04	494.04	494.04	494.04	494.04	494.04	494.04	494.04	
	D			494.04	494.04	494.04	494.04	494.04			494.29			494.04	494.04	494.04	494.04	494.04	494.04	494.04	494.04	494.04	494.04	494.04	494.04	494.04	
Dalles	Z			494.26	494.26	494.26	494.26	494.26			494.35			494.26	494.26	494.26	494.26	494.26	494.26	494.26	494.26	494.26	494.26	494.26	494.26	494.26	
	D			494.26	494.26	494.26	494.26	494.26			494.35			494.26	494.26	494.26	494.26	494.26	494.26	494.26	494.26	494.26	494.26	494.26	494.26	494.26	
GNT 20	Z			493.89	493.89	493.89	493.89	493.89			494.11			493.89	493.89	493.89	493.89	493.89	493.89	493.89	493.89	493.89	493.89	493.89	493.89	493.89	
	D			493.89	493.89	493.89	493.89	493.89			494.11			493.89	493.89	493.89	493.89	493.89	493.89	493.89	493.89	493.89	493.89	493.89	493.89	493.89	
Fond de forme	Z			493.86	493.86	493.86	493.86	493.86			494.01			493.86	493.86	493.86	493.86	493.86	493.86	493.86	493.86	493.86	493.86	493.86	493.86	493.86	
	D			493.86	493.86	493.86	493.86	493.86			494.01			493.86	493.86	493.86	493.86	493.86	493.86	493.86	493.86	493.86	493.86	493.86	493.86	493.86	

Carnet de profils en travers - RD

Axe : Axe
 N° profil : 89
 Pk : 232.536m

 Z Tn : 494.35
 Z Projet : 494.44

 Section remblais : 0.0
 Section déblais : 3.99

 Echelle X : 1/50
 Echelle Z : 1/50

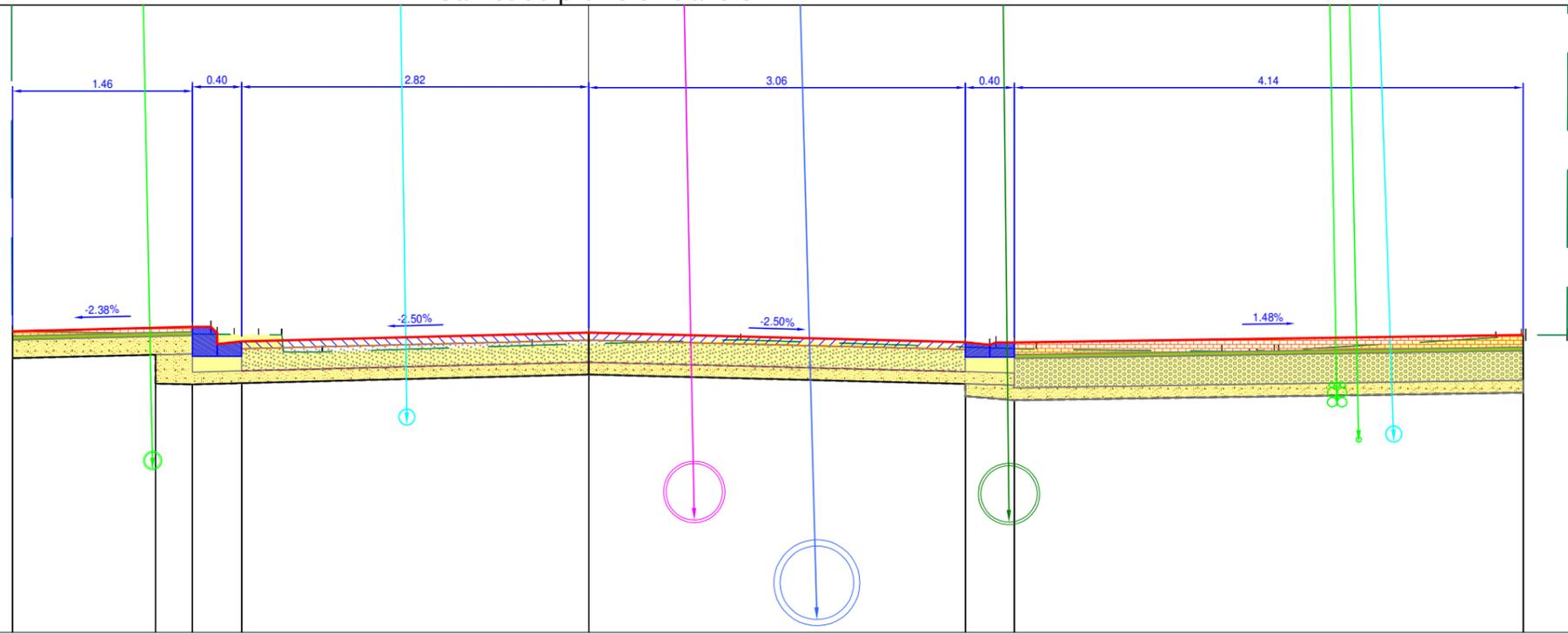

Plan Comp : 492.0

Terrain	Z	-5.686	-499.00	-4.698	499.00	-4.686	488.90	-2.886	494.42	-2.687	494.42	-2.498	494.42	-2.170	494.28	-2.166	494.28	-0.460	494.34	0.000	494.35	1.236	494.38	3.640	494.30	5.149	494.29	5.377	494.26	5.457	494.26	5.575	494.29	5.610	494.29	7.377	494.40	7.585	494.42	7.959	494.42	8.600	498.00				
	D		0.988			1.812					1.705							0.460				1.236				1.509											0.338			0.634							
GC	Z																																														
	D																																														
Projet	Z																																														
	D																																														
Ecart entre Projet - Terrain																																															
BBSG	Z																																														
	D																																														
GB	Z																																														
	D																																														
Dalles	Z																																														
	D																																														
GNT 20	Z																																														
	D																																														
Fond de forme	Z																																														
	D																																														

Carnet de profils en travers - RD

Axe : Axe
 N° profil : 97
 Pk : 248.155m

Z Tn : 494.74
 Z Projet : 494.82

Section remblais : 0.0
 Section déblais : 3.74

Echelle X : 1/50
 Echelle Z : 1/50

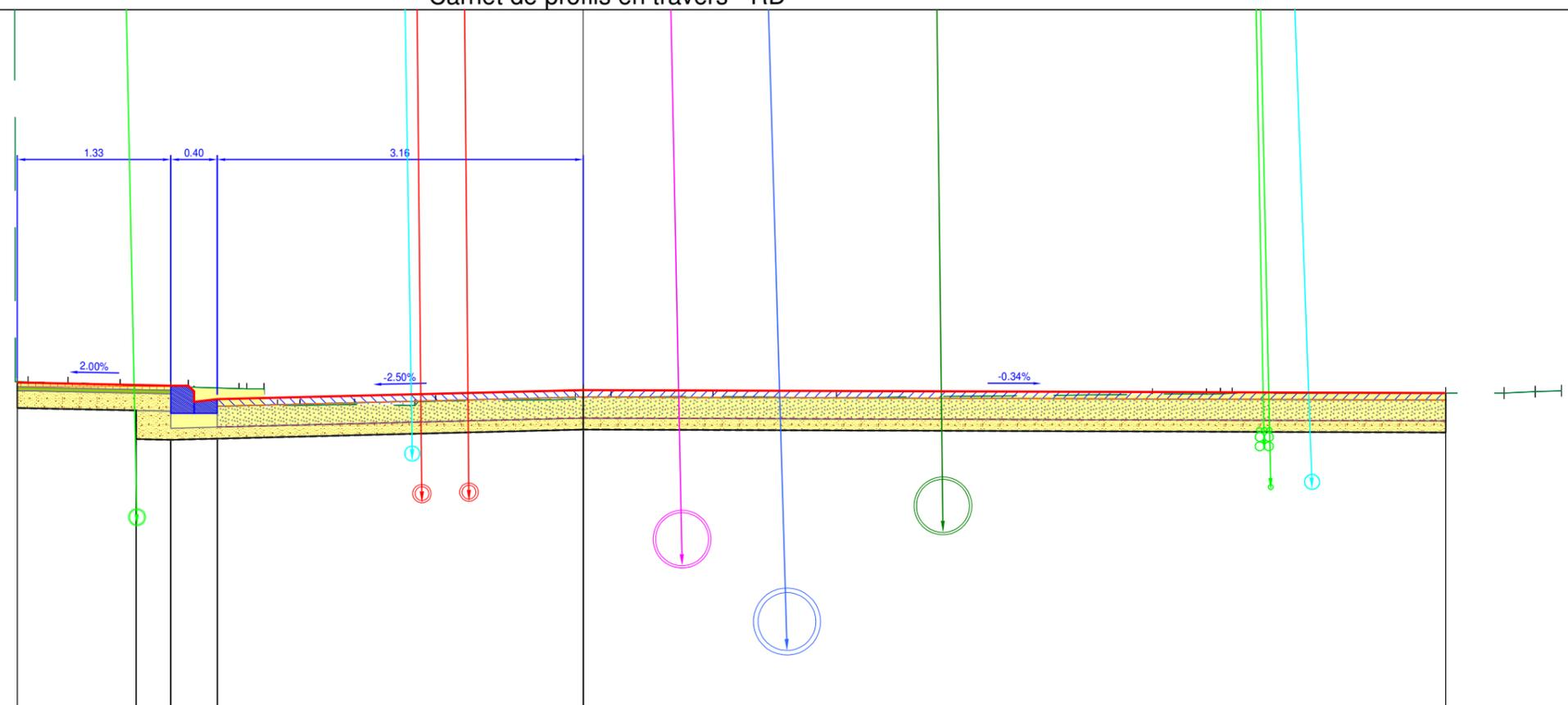

Plan Comp : 492.0

Terrain	Z	499.00	499.00	499.00	499.00	494.88	494.86	494.83	494.83	494.73	494.76	494.75	494.78	494.78	494.79	494.80	494.81																		
	D	5.890	5.461	5.184	4.913	4.796	4.450	4.000	2.974	2.905	2.757	2.641	2.446	1.974	1.453	1.275	0.067	0.243	0.880	1.122	1.067	2.190	2.729	4.919	5.386	5.507	5.607	7.956	8.226	8.452					
Projet	Z																																		
	D	0.429							3.562	3.412	3.362	3.162																							
Ecart entre Projet - Terrain																																			
BBSG	Z																																		
	D																																		
GB	Z																																		
	D																																		
Dalles	Z																																		
	D																																		
GNT 20	Z																																		
	D																																		
Fond de forme	Z																																		
	D																																		

Carnet de profils en travers - RD

Axe : Axe
 N° profil : 107
 Pk : 279.221m

 Z Tn : 495.53
 Z Projet : 495.57

 Section remblais : 0.0
 Section déblais : 3.9

 Echelle X : 1/50
 Echelle Z : 1/50

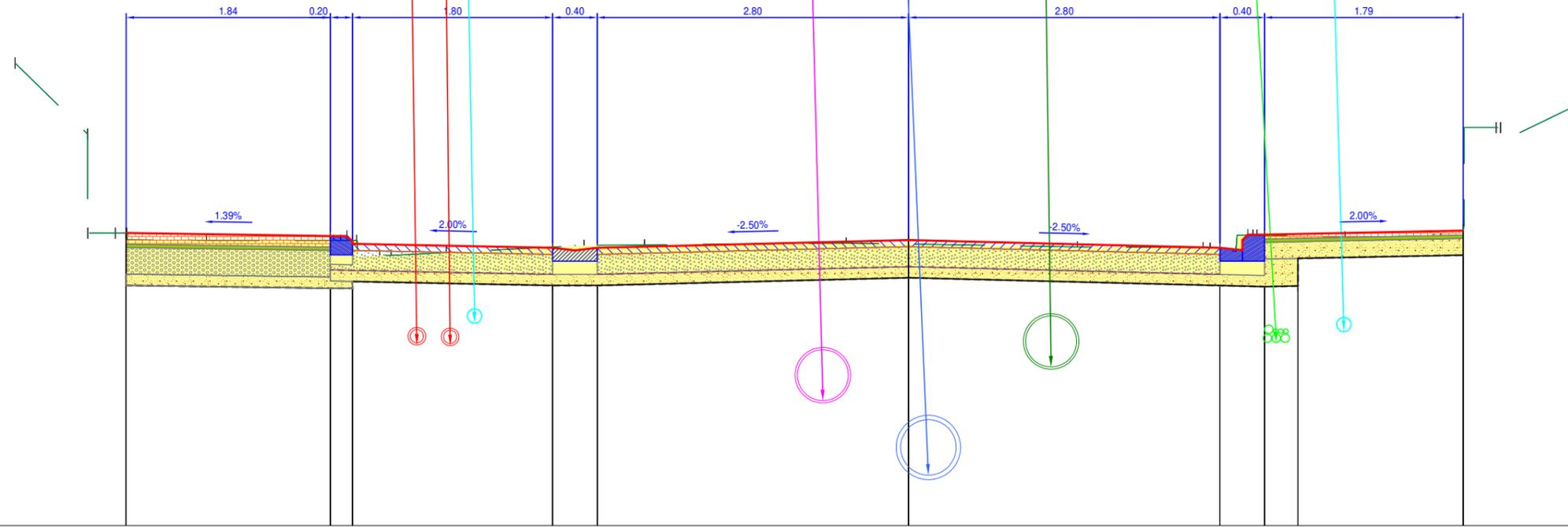

Plan Comp : 493.0

Terrain	Z	-8.035	0.651	-7.384	-7.133	-7.035	-7.029	-6.315	1.146	-5.169	-5.007	-4.968	-4.757	-4.653	-4.157	1.237	-2.920	-2.376	1.815	-0.561	0.000	1.516	2.648	2.944	3.097	3.132	0.791	3.923	4.718	4.784	4.986	5.283	5.323	5.986				
	D																																					
GC	Z																																					
	D																																					
Projet	Z																																					
	D																																					
Ecart entre Projet - Terrain																																						
BBSG	Z																																					
	D																																					
GB	Z																																					
	D																																					
Dalles	Z																																					
	D																																					
GNT 20	Z																																					
	D																																					
Fond de forme	Z																																					
	D																																					

Carnet de profils en travers - RD

Axe : Axe
 N° profil : 108
 Pk : 282.743m
 Z Tn : 495.61
 Z Projet : 495.65

Section remblais : 0.0
 Section déblais : 3.45

Echelle X : 1/50
 Echelle Z : 1/50

Plan Comp : 493.0

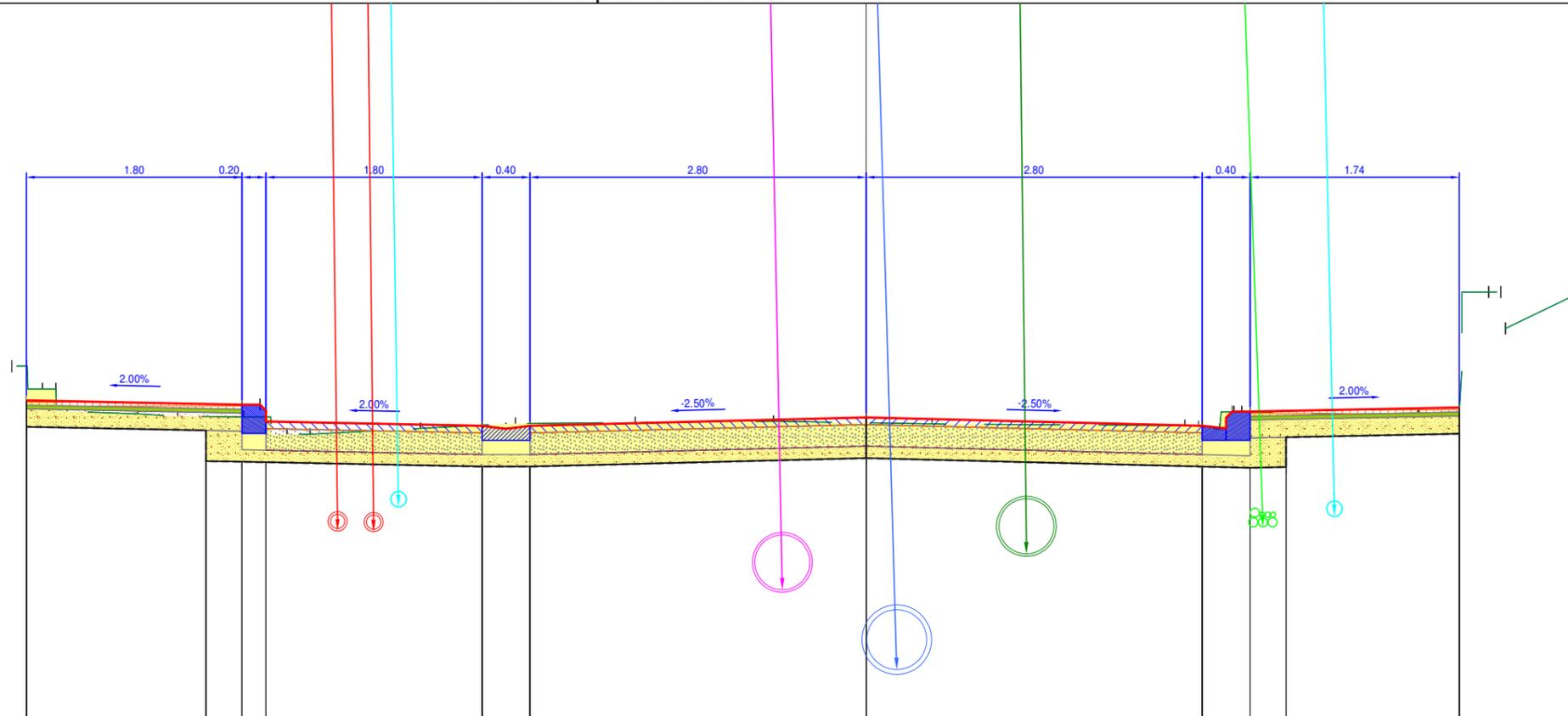

Terrain	Z	-7.997	-500.00	-7.300	-500.00	-7.119	-486.08	-6.997	-486.08	-6.864	-485.89	-6.752	-485.89	-6.632	-485.51	-3.715	-485.56	-2.923	-485.60	-1.923	-485.61	-0.771	-485.62	0.000	-485.61	0.548	-485.60	2.656	-485.58	2.772	-485.58	2.947	-485.55	3.066	-485.70	3.130	-485.70	4.595	-485.67	4.944	-485.69	5.188	-486.70	5.328	-486.39	5.944	-486.69	
	D	0.697		0.678		0.334		0.548		0.917		0.792		1.000		1.152		0.771		0.548		2.108		0.548		2.108		2.656		2.772		2.947		3.066		3.130		1.464		0.330		4.944		0.615		5.944		
Projet	Z																																															
	D																																															
Ecart entre Projet - Terrain																																																
BBSG	Z																																															
	D																																															
GB	Z																																															
	D																																															
Dalles	Z																																															
	D																																															
GNT 20	Z																																															
	D																																															
Fond de forme	Z																																															
	D																																															

Carnet de profils en travers - RD

Axe : Axe
 N° profil : 112
 Pk : 292.961m

Z Tn : 495.85
 Z Projet : 495.9

Section remblais : 0.0
 Section déblais : 3.91

Echelle X : 1/50
 Echelle Z : 1/50

Plan Comp : 493.5

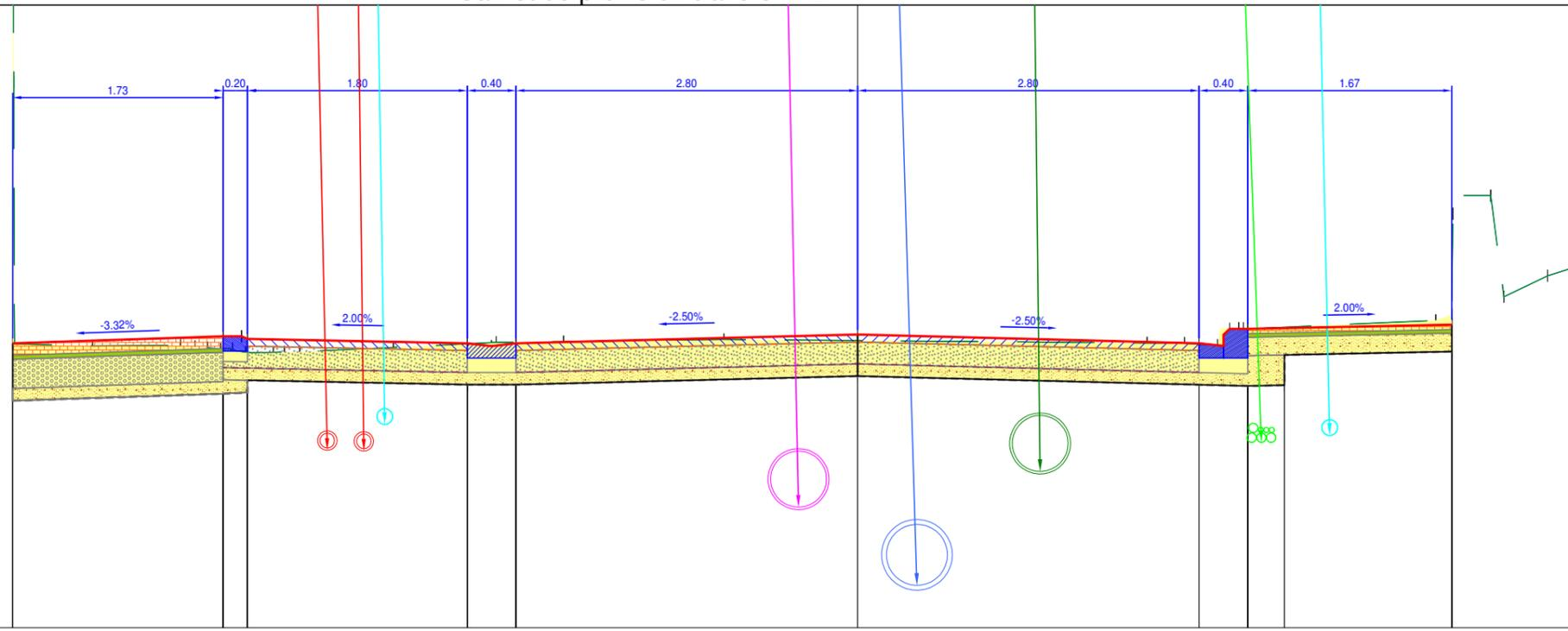

Terrain	Z	500.00	500.00	500.00	495.81	495.81	495.80	495.84	495.84	495.86	495.85	495.83	495.83	495.81	495.95	496.02	496.06	496.89	497.04	496.21	496.38	496.45	
	D	7.926	7.493	7.077	6.926	6.926	6.926	6.926	6.926	6.926	6.926	6.926	6.926	6.926	6.926	6.926	6.926	6.926	6.926	6.926	6.926	6.926	6.926
GC	Z			495.46	495.76	495.76																	
	D			6.926	1.726	5.200																	
Projet	Z			495.83	495.89	495.89	495.83	495.81	495.83	495.90	495.90	495.83	495.83	495.81	495.95	495.98	495.98	495.98	495.98	495.98	495.98	495.98	495.98
	D			6.926	1.726	5.000	1.800	3.200	3.000	0.000	0.000	2.800	2.800	3.000	3.200	4.870	4.870	4.870	4.870	4.870	4.870	4.870	4.870
Ecart entre Projet - Terrain				-4.17	-0.11	-0.11	1.800	-3.200	-3.000	0.000	0.000	2.800	2.800	3.000	3.200	-0.08	-0.08	-0.08	-0.08	-0.08	-0.08	-0.08	-0.08
BBSG	Z			495.81	495.81	495.81	495.83	495.83	495.90	495.90	495.90	495.83	495.83	495.81	495.95	495.98	495.98	495.98	495.98	495.98	495.98	495.98	495.98
	D			5.000	1.800	3.200	0.400	2.800	2.800	0.000	0.000	2.800	2.800	3.000	3.200	4.870	4.870	4.870	4.870	4.870	4.870	4.870	4.870
GB	Z			495.68	495.68	495.68	495.77	495.77	495.84	495.84	495.84	495.77	495.77	495.68	495.83	495.83	495.83	495.83	495.83	495.83	495.83	495.83	495.83
	D			5.000	1.800	3.200	0.400	2.800	2.800	0.000	0.000	2.800	2.800	3.000	3.200	4.870	4.870	4.870	4.870	4.870	4.870	4.870	4.870
Dalles	Z			495.63	495.63	495.63	495.63	495.63	495.66	495.66	495.66	495.63	495.63	495.63	495.73	495.73	495.73	495.73	495.73	495.73	495.73	495.73	495.73
	D			6.926	1.726	5.200	8.400	8.400	8.400	8.400	8.400	8.400	8.400	8.400	8.400	8.400	8.400	8.400	8.400	8.400	8.400	8.400	8.400
GNT 20	Z			495.36	495.36	495.36	495.59	495.59	495.66	495.66	495.66	495.59	495.59	495.59	495.66	495.66	495.66	495.66	495.66	495.66	495.66	495.66	495.66
	D			6.926	1.726	5.000	1.800	3.200	0.000	0.000	0.000	2.800	2.800	3.200	3.500	4.870	4.870	4.870	4.870	4.870	4.870	4.870	4.870
Fond de forme	Z			495.42	495.42	495.42	495.49	495.49	495.56	495.56	495.56	495.49	495.49	495.49	495.56	495.56	495.56	495.56	495.56	495.56	495.56	495.56	495.56
	D			6.926	1.726	5.000	1.800	3.200	0.000	0.000	0.000	2.800	2.800	3.200	3.500	4.870	4.870	4.870	4.870	4.870	4.870	4.870	4.870

Carnet de profils en travers - RD

Axe : Axe
 N° profil : 118
 Pk : 314.583m

Z Tn : 496.39
 Z Projet : 496.43

Section remblais : 0.0
 Section déblais : 3.56

Echelle X : 1/50
 Echelle Z : 1/50

Plan Comp : 493.5

Terrain	Z	-8.001	-7.984	-7.302	-7.201	-7.053	-6.275	-5.155	-3.025	-4.846	-4.590	-3.911	-2.986	-2.021	-1.227	0.000	0.454	0.454	2.695	2.848	3.000	3.050	3.182	3.933	4.737	4.742	5.059	5.319	5.331	5.743	
	D	0.662	0.725	0.725	0.725	0.725	0.725	0.725	0.725	0.725	0.725	0.679	0.925	0.966	0.793	1.227	0.454	0.454	2.241	2.800	2.800	3.000	3.200	0.751	3.933	0.804	0.316	5.059	5.319	5.331	5.743
Projet	Z			-496.45				496.41	496.41	496.39	496.26	496.31	496.37	496.40	496.42	496.39	496.38		496.35	496.34	496.32	496.47		496.48	496.49	496.49	497.50	487.50	487.09	496.68	
	D			-7.001			1.800	-5.200	-5.000	-5.000	-4.590	-3.200	-3.000	-2.800	-2.021	-1.227	0.000	0.454		2.800	2.800	3.000	3.200	0.751	3.933	0.804	0.316	5.059	5.319	5.331	5.743
Ecart entre Projet - Terrain				-0.01			1.800	-0.00	-0.01	-0.01	0.679	0.925	0.966	0.793	1.227	0.454	0.454		0.00	0.00	0.00	0.00	0.00	0.751	0.804	-0.17	0.316	5.059	5.319	5.331	5.743
BBSG	Z							496.33	496.33	496.33	496.26	496.31	496.37	496.40	496.42	496.39	496.38		496.35	496.34	496.32	496.47		496.48	496.49	496.49	497.50	487.50	487.09	496.68	
	D						1.800	-5.000	-5.000	-5.000	-4.590	-3.200	-3.000	-2.800	-2.021	-1.227	0.000	0.454		2.800	2.800	3.000	3.200	0.751	3.933	0.804	0.316	5.059	5.319	5.331	5.743
GB	Z							496.21	496.16	496.20	496.33	496.31	496.37	496.40	496.42	496.39	496.38		496.35	496.34	496.32	496.47		496.48	496.49	496.49	497.50	487.50	487.09	496.68	
	D						1.800	-5.200	-5.000	-5.000	-4.590	-3.200	-3.000	-2.800	-2.021	-1.227	0.000	0.454		2.800	2.800	3.000	3.200	0.751	3.933	0.804	0.316	5.059	5.319	5.331	5.743
Dalles	Z			496.41	496.45			496.41											496.35	496.34	496.32	496.47		496.48	496.49	496.49	497.50	487.50	487.09	496.68	
	D			-7.001		1.800		-5.200												2.800	2.800	3.000	3.200	0.751	3.933	0.804	0.316	5.059	5.319	5.331	5.743
GNT 20	Z			496.23	496.38			496.06	496.06	496.19	496.15								496.12	496.12	496.26	496.41		496.48	496.49	496.49	497.50	487.50	487.09	496.68	
	D			-7.001		1.500		-5.500	-5.200	-5.000	-5.000	1.800								2.800	2.800	3.200	3.500	1.243	3.933	0.804	0.316	5.059	5.319	5.331	5.743
Fond de forme	Z			496.45	496.33			496.06	496.06	496.19	496.15								496.12	496.12	496.26	496.41		496.48	496.49	496.49	497.50	487.50	487.09	496.68	
	D			-7.001		1.500		-5.500	-5.200	-5.000	-5.000	1.800								2.800	2.800	3.200	3.500	1.243	3.933	0.804	0.316	5.059	5.319	5.331	5.743

Carnet de profils en travers - RD

Axe : Axe
 N° profil : 120
 Pk : 319.668m

Z Tn : 496.53
 Z Projet : 496.56

Section remblais : 0.0
 Section déblais : 4.1

Echelle X : 1/50
 Echelle Z : 1/50

Plan Comp : 494.5

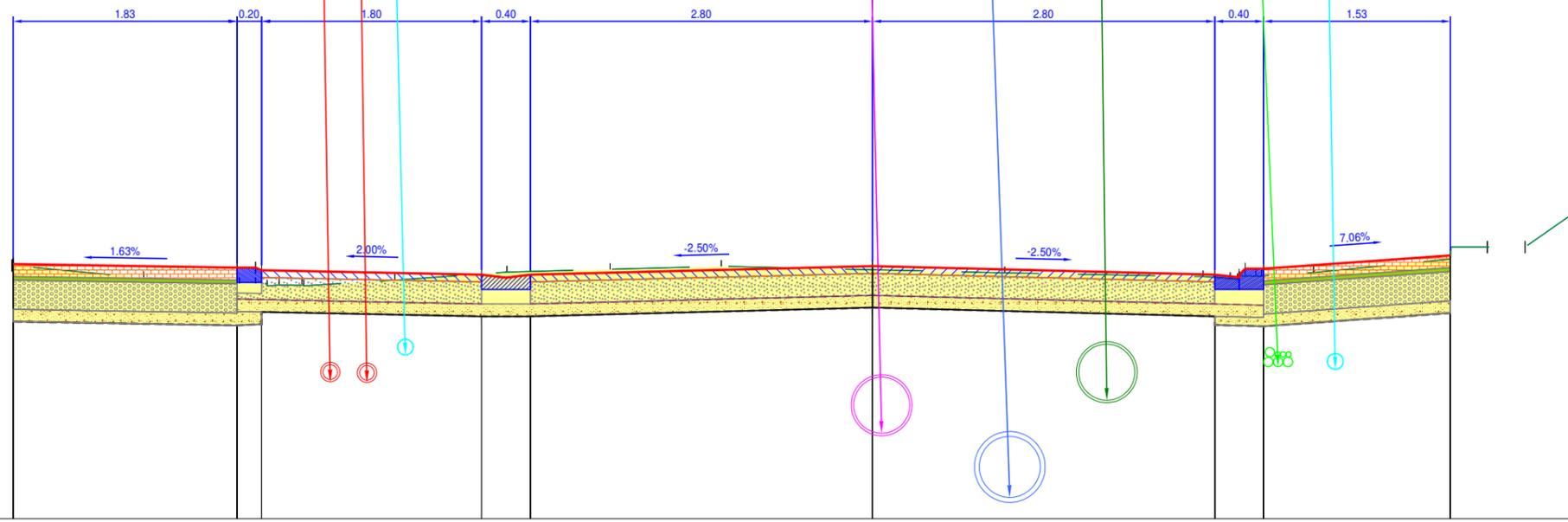

Terrain	Z	500.00	500.00	496.47	496.42	496.42	496.45	496.45	496.52	496.54	496.56	496.53	496.51	496.48	496.46	496.48	496.51	496.62	496.72	496.99
	D	0.333	0.361	1.070	0.783	1.833	0.746	0.917	2.992	0.844	1.239	0.000	1.081	1.081	1.624	2.705	0.423	1.121	5.031	5.341
GC	Z																			
	D																			
Projet	Z																			
	D																			
Ecart entre Projet - Terrain																				
BBSG	Z																			
	D																			
GB	Z																			
	D																			
Dalles	Z																			
	D																			
GNT 20	Z																			
	D																			
Fond de forme	Z																			
	D																			

Carnet de profils en travers - RD

Axe : Axe
 N° profil : 121
 Pk : 320.378m

Z Tn : 496.55
 Z Projet : 496.58

Section remblais : 0.0
 Section déblais : 4.13

Echelle X : 1/50
 Echelle Z : 1/50

Plan Comp : 494.5

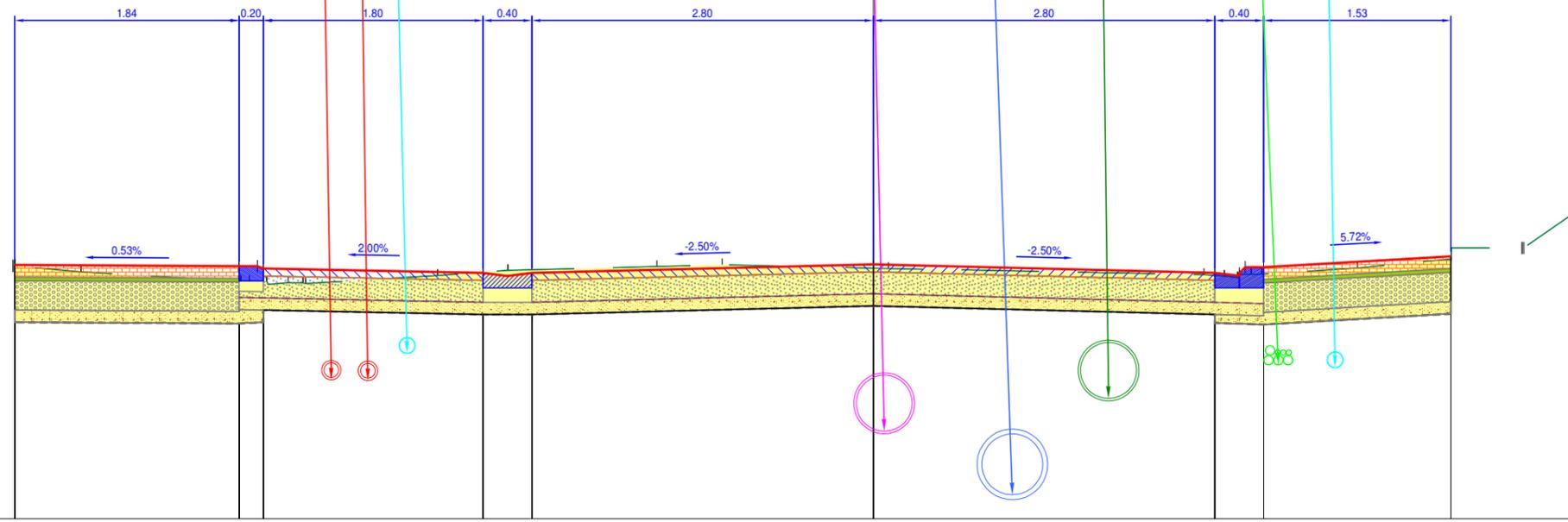

Terrain	Z	-8.038	-500.00	-7.339	500.00	-7.051	496.57	-6.496	496.52	-5.184	496.44	-4.797	496.43	-4.873	496.44	-3.571	496.49	-2.996	496.54	-1.776	496.57	-1.240	496.58	0.000	496.55	2.710	496.50	2.877	496.49	2.965	496.48	3.185	496.50	3.968	496.56	4.734	496.63	5.317	496.72	5.734	497.00		
	D	-7.942	500.00	-7.334	497.59	-7.038	496.57	-6.496	496.52	-5.114	496.44	-4.973	496.44	-4.873	496.43	-3.571	496.49	-2.996	496.54	-1.776	496.57	-1.240	496.58	0.000	496.55	2.710	496.50	2.877	496.49	2.965	496.48	3.185	496.50	3.968	496.56	4.734	496.63	5.317	496.72	5.734	497.00		
GC	Z																																										
	D																																										
Projet	Z																																										
	D																																										
Ecart entre Projet - Terrain																																											
BBSG	Z																																										
	D																																										
GB	Z																																										
	D																																										
Dalles	Z																																										
	D																																										
GNT 20	Z																																										
	D																																										
Fond de forme	Z																																										
	D																																										

Carnet de profils en travers - RD

Axe : Axe
 N° profil : 124
 Pk : 330.000m

 Z Tn : 496.87
 Z Projet : 496.88

 Section remblais : 0.0
 Section déblais : 3.93

 Echelle X : 1/50
 Echelle Z : 1/50

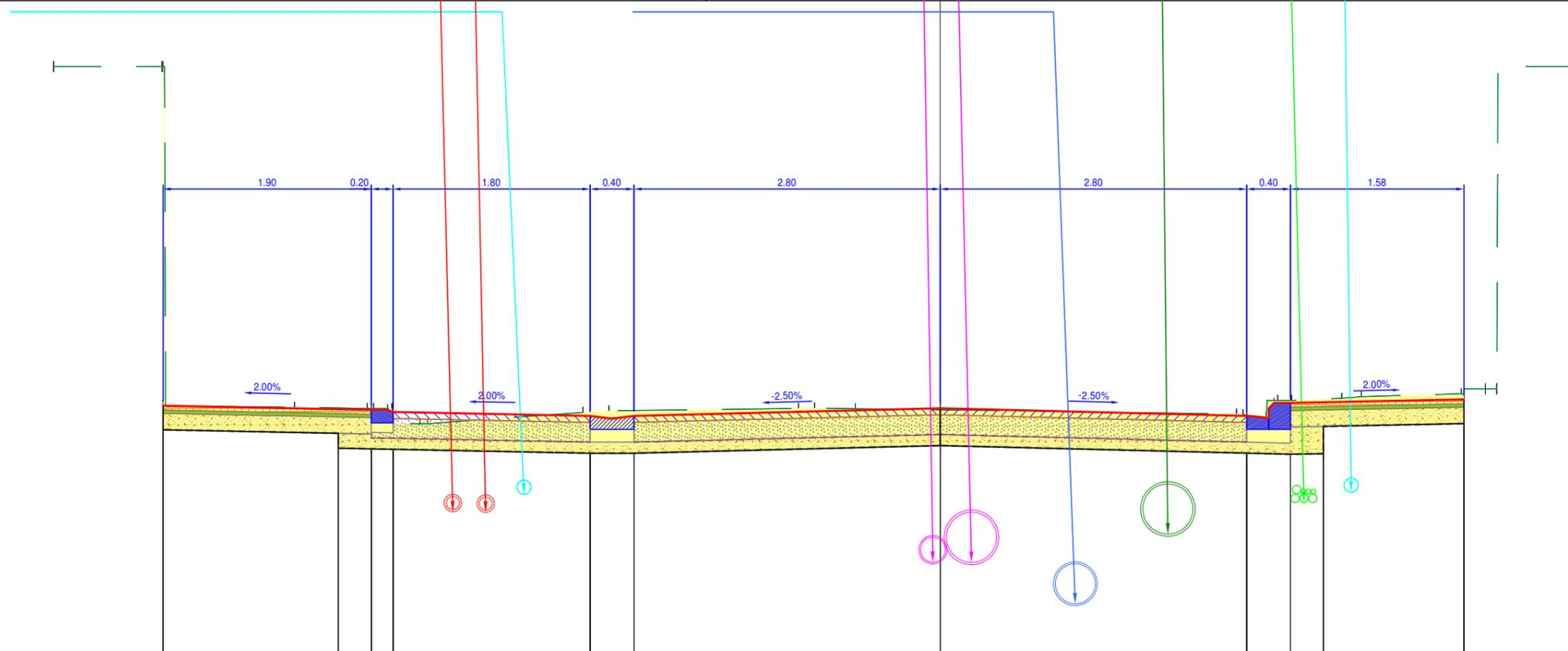

Plan Comp : 494.5

Terrain	Z	-8.100	-500.00	-7.111	500.00	-5.899	496.89	-5.236	496.88	-4.756	496.74	-3.264	496.85	-1.296	496.88	0.000	496.87	2.706	496.83	2.978	496.80	3.084	496.95	3.667	496.97	4.760	497.01	4.980	497.06	5.083	497.06	5.091	496.97	5.784	500.00			
	D	0.989	-7.100	1.201	0.663	5.236	5.010	4.756	1.421	3.264	3.028	1.731	1.296	0.373	0.775	0.000	2.706	2.706	2.978	3.084	3.211	0.456	3.667	3.847	0.913	4.760	4.784	4.980	5.083	5.091	0.693	5.784	5.784					
Projet	Z		-496.91																																			
	D		-7.100	1.900					1.800								2.800		2.800																			
Ecart entre Projet - Terrain			-3.09					-0.01																														
BBSG	Z																																					
	D																																					
GB	Z																																					
	D																																					
Dalles	Z																																					
	D																																					
GNT 20	Z																																					
	D																																					
Fond de forme	Z																																					
	D																																					

Carnet de profils en travers - RD

Axe : Axe
 N° profil : 126
 Pk : 331.734m

Z Tn : 496.93
 Z Projet : 496.94

Section remblais : 0.0
 Section déblais : 3.76

Echelle X : 1/50
 Echelle Z : 1/50

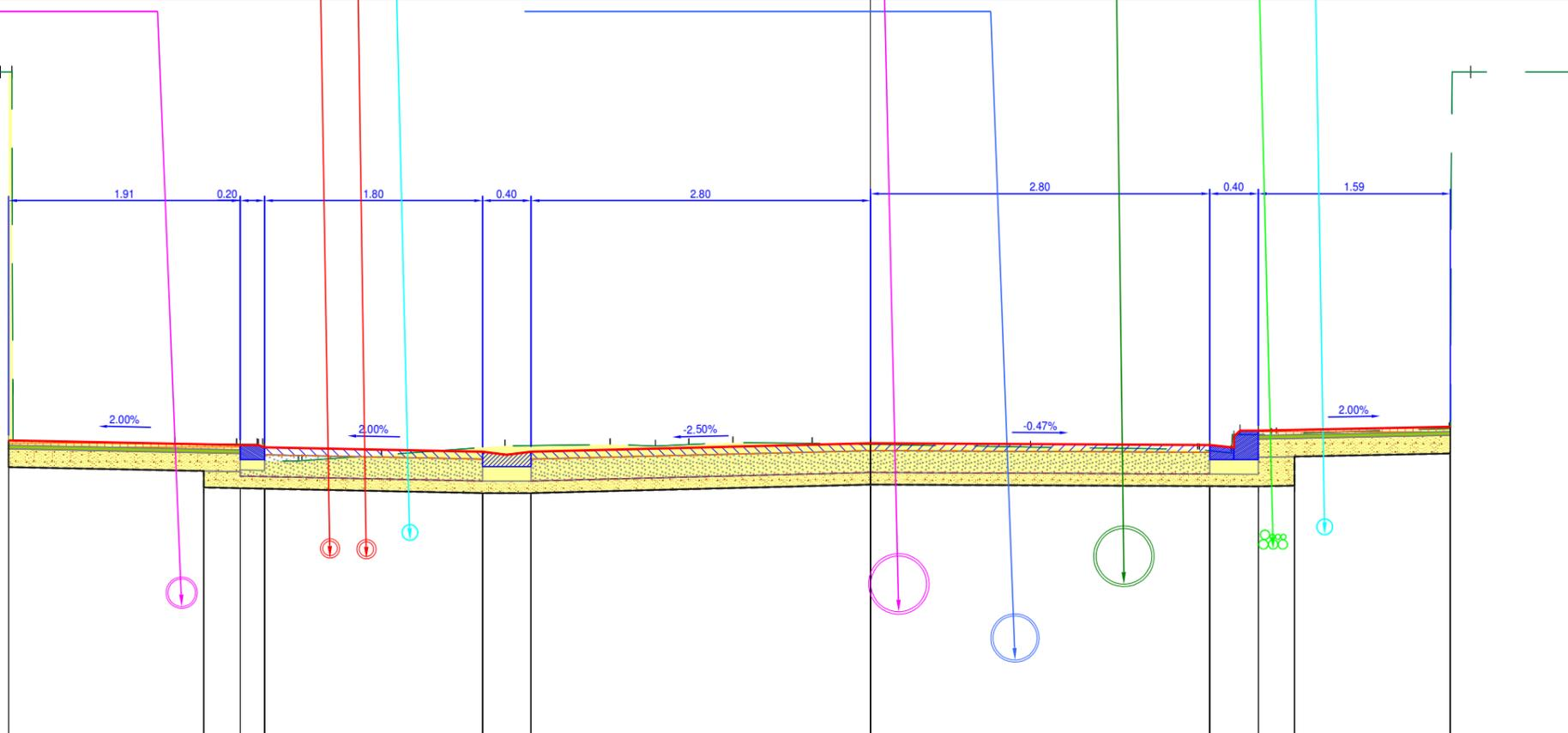

Plan Comp : 494.5

Terrain	Z	-8.111	-500.00	-7.180	-500.00	-5.739	-496.94	-5.229	-496.93	-4.730	-496.80	-4.035	-496.85	-3.015	-496.92	-2.148	-496.93	-1.773	-496.92	-1.498	-496.93	-1.133	-496.95	-0.654	-0.479	-496.94	0.000	-496.93	1.322	1.322	-496.91	2.701	496.89	2.715	496.89	2.978	496.88	3.201	497.01	3.381	497.02	4.778	-497.06	4.953	-500.00	5.787	-500.00					
	D			0.931		1.337		0.510		0.656		1.019		0.868		0.375		1.773		1.498		1.133		0.654		0.479		0.000		1.322		1.322		2.701		2.715		2.978		3.201		3.381		4.778		4.953		5.787				
Projet	Z			-7.111	-496.96			-5.200	-496.93	-5.060	-496.93			-3.200	-496.87												0.000	-496.94																								
	D			-7.111				-5.060		-5.000				-3.200														0.000																								
Ecart entre Projet - Terrain				-3.04				-0.01		-0.11				-0.05													-0.01																									
BBSG	Z							-496.85		-496.81				-496.87													-496.94																									
	D							-5.000		-5.000				-3.200													0.000																									
GB	Z							-496.72		-496.67				-496.81													-496.88																									
	D							-5.200		-5.000				-3.200													0.000																									
Dalles	Z							-496.93		-496.93				-496.87													-496.94																									
	D							-5.200		-5.000				-3.200													0.000																									
GNT 20	Z							-496.74		-496.71				-496.63													-496.70																									
	D							-7.111		-5.500				-3.200													0.000																									
Fond de forme	Z							-496.57		-496.57				-496.53													-496.54																									
	D							-5.200		-5.000				-3.200													0.000																									

Carnet de profils en travers - RD

Axe : Axe
 N° profil : 132
 Pk : 353.261m

Z Tn : 497.74
 Z Projet : 497.75

Section remblais : 0.0
 Section déblais : 4.98

Echelle X : 1/50
 Echelle Z : 1/50

Plan Comp : 495.7

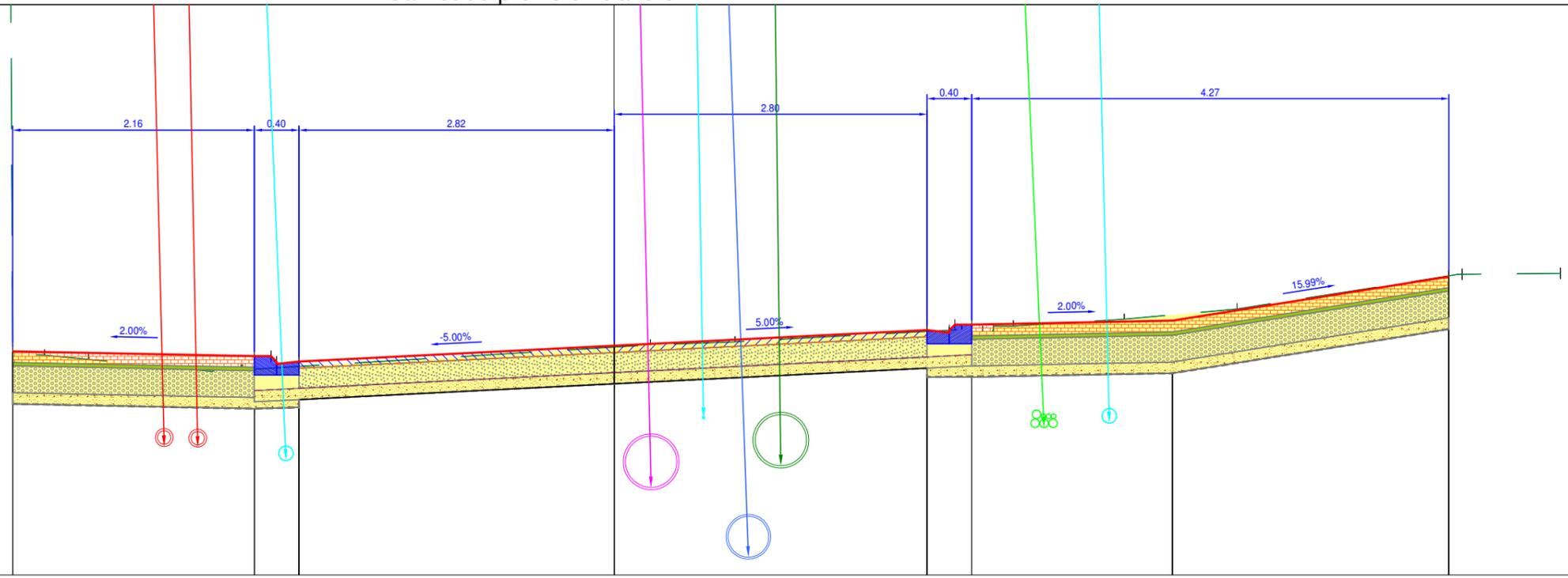

Terrain	Z	-6.384	-5.712	-5.466	-5.098	-4.705	-3.589	-3.339	-3.328	0.000	0.324	0.759	1.082	2.030	3.113	3.297	3.385	3.574	0.992	4.566	5.575	7.472	7.591	8.472
	D	0.673		5.466	5.098	4.705	3.589	3.339	3.328															
GC	Z			497.33				497.53							497.81					497.84		498.24	498.00	
	D			5.384			2.163	3.221		6.421					3.200					4.999		7.472	7.472	
Projet	Z			497.70				497.66		497.75					497.89					497.97		498.37		
	D			5.384			2.163	3.221		0.000		2.800			2.800		3.000	3.050	3.200	4.999		7.472	7.472	
Ecart entre Projet - Terrain				-0.02				-0.12		-0.01					-0.01		-0.05		-0.05			-0.01		
BBSG	Z							497.55		497.75					497.83					497.84		498.24	498.00	
	D						2.163	2.821		0.000		2.800			2.800					4.999		7.472	7.472	
GB	Z							497.37		497.69					497.83					497.84		498.24	498.00	
	D						2.163	2.821		0.000		2.800			2.800					4.999		7.472	7.472	
Dalles	Z			497.60				497.66		497.75					497.83					497.84		498.24	498.00	
	D			5.384			2.163	3.221		6.421					3.200					4.999		7.472	7.472	
GNT 20	Z			497.33				497.35		497.51					497.55					497.60		498.00	497.90	
	D			5.384			2.163	3.221		0.000		2.800			2.800		0.400	3.200		4.999		7.472	7.472	
Fond de forme	Z			497.33				497.27		497.41					497.47					497.50		497.90	498.00	
	D			5.384			2.163	3.221		0.000		2.800			2.800		0.400	3.200		4.999		7.472	7.472	

Axe : Axe
 N° profil : 138
 Pk : 366.681m

Z Tn : 498.15
 Z Projet : 498.16

Section remblais : 0.0
 Section déblais : 4.04

Echelle X : 1/50
 Echelle Z : 1/50

Plan Comp : 496.0

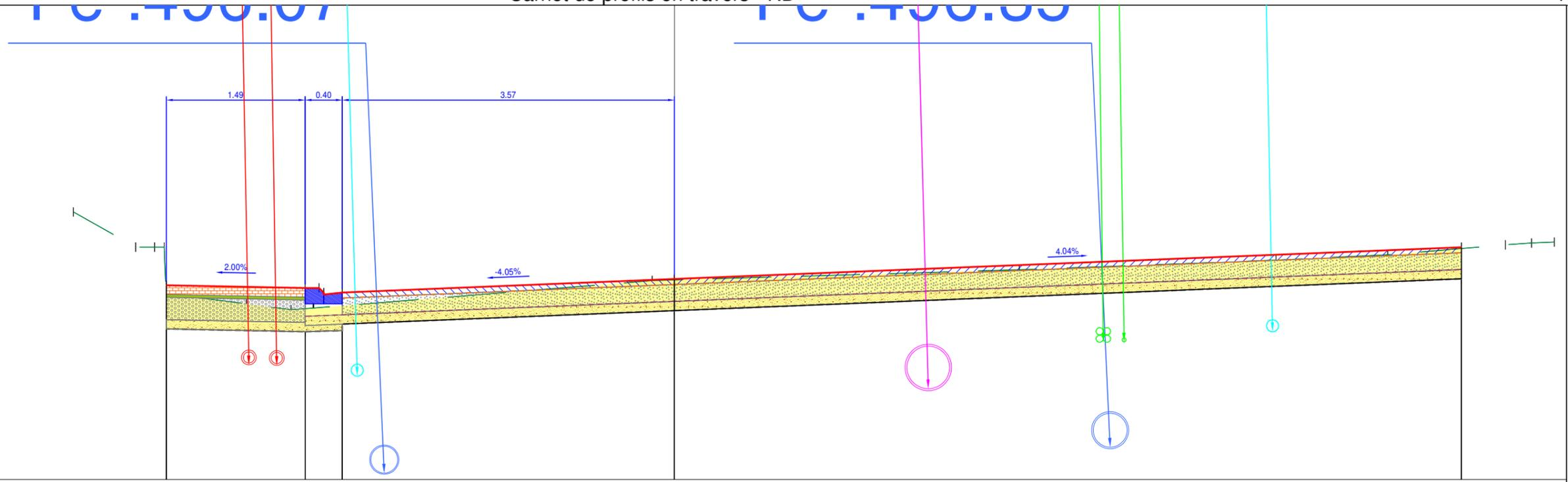

Terrain	Z	498.88	498.50	498.50	498.32	497.89	497.83	497.84	498.14	498.15	498.26	498.36	498.42	498.52	498.54	498.55
	D	-6.465	0.672	-5.794	-5.592	-5.488	-4.604	-4.124	-3.886	-0.238	0.000	3.711	2.761	7.674	8.939	9.220
GC	Z		497.96	497.96	497.96	497.93	497.93	497.93	498.16	498.16	498.16	498.16	498.16	498.16	498.16	498.16
	D		-5.465	-5.465	-5.465	1.493	-3.972	-3.972	0.000	0.000	3.711	2.761	1.203	7.674	8.939	9.220
Projet	Z		498.09	498.09	498.09	498.06	498.06	498.01	498.16	498.16	498.16	498.16	498.16	498.16	498.16	498.16
	D		-5.465	-5.465	-5.465	1.493	-3.972	-3.972	0.000	0.000	3.711	2.761	1.203	7.674	8.939	9.220
Ecart entre Projet - Terrain			-0.09	-0.09	-0.09	0.07	0.07	0.07	0.00	0.00	0.00	0.00	0.00	0.00	0.00	0.00
BBSG	Z		497.95	497.95	497.95	497.95	497.95	497.95	498.16	498.16	498.16	498.16	498.16	498.16	498.16	498.16
	D		-3.572	-3.572	-3.572	3.572	3.572	3.572	0.000	0.000	3.711	2.761	1.203	7.674	8.939	9.220
GB	Z		497.95	497.95	497.95	497.95	497.95	497.95	498.10	498.10	498.10	498.10	498.10	498.10	498.10	498.10
	D		-3.572	-3.572	-3.572	3.572	3.572	3.572	0.000	0.000	3.711	2.761	1.203	7.674	8.939	9.220
Dalles	Z		497.99	497.99	497.99	497.99	497.99	497.99	498.06	498.06	498.06	498.06	498.06	498.06	498.06	498.06
	D		-5.465	-5.465	-5.465	1.493	-3.972	-3.972	0.000	0.000	3.711	2.761	1.203	7.674	8.939	9.220
GNT 20	Z		497.62	497.62	497.62	497.62	497.62	497.62	497.92	497.92	497.92	497.92	497.92	497.92	497.92	497.92
	D		-5.465	-5.465	-5.465	1.493	-3.972	-3.972	0.000	0.000	3.711	2.761	1.203	7.674	8.939	9.220
Fond de forme	Z		497.67	497.67	497.67	497.67	497.67	497.67	498.16	498.16	498.16	498.16	498.16	498.16	498.16	498.16
	D		-3.572	-3.572	-3.572	3.572	3.572	3.572	0.000	0.000	3.711	2.761	1.203	7.674	8.939	9.220

Carnet de profils en travers - RD

Axe : Axe
 N° profil : 143
 Pk : 381.667m

Z Tn : 498.36
 Z Projet : 498.37

Section remblais : 0.0
 Section déblais : 3.67

Echelle X : 1/50
 Echelle Z : 1/50

Plan Comp : 496.0

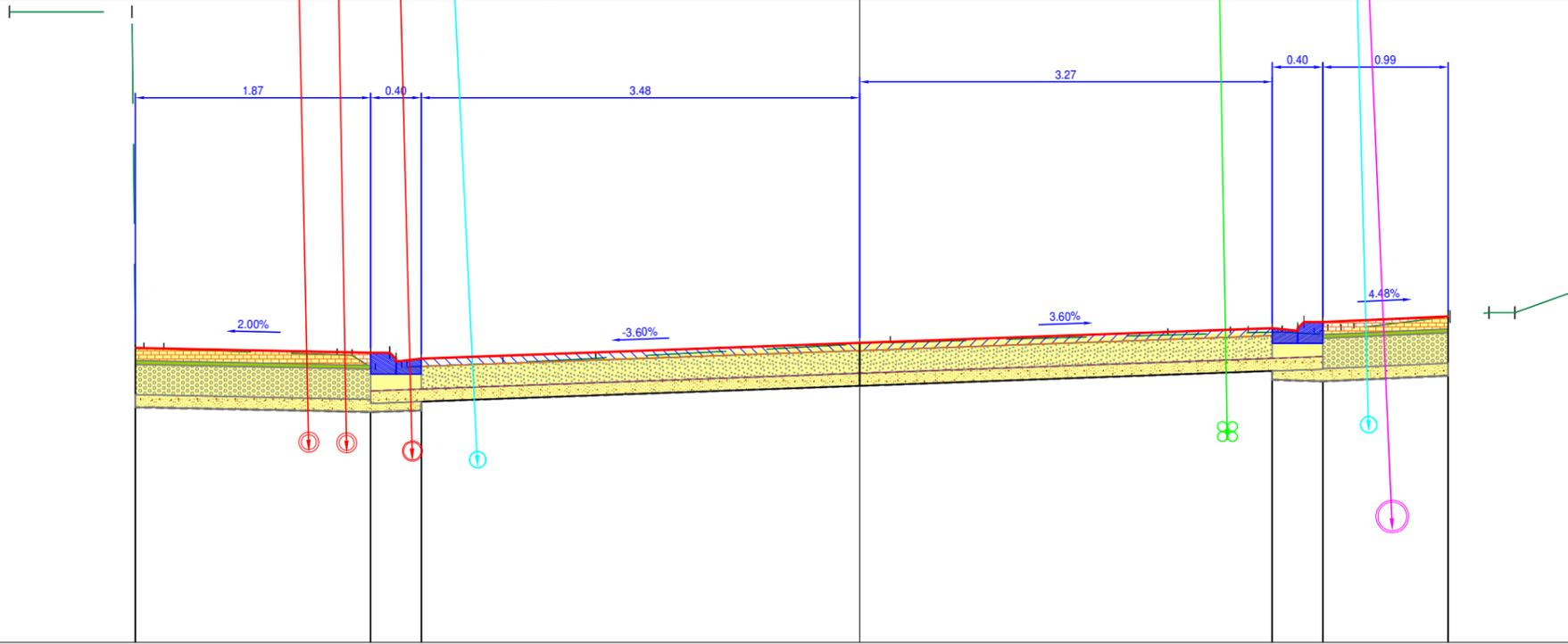

Terrain	Z	-6.744	501.00	498.33	498.33	-4.146	498.28	498.27	498.16	498.18	498.21	498.25	498.36	498.38	498.44	498.45	498.46	498.45	498.45	498.45	498.47	498.58	498.61	498.61	498.78
	D			0.971	1.373	1.866	3.478	7.550	3.273	0.994	4.667	5.667													
GC	Z		497.96	498.20	498.17	498.30	498.30	498.25	498.25	498.37	498.37	498.37	498.45	498.45	498.45	498.45	498.45	498.45	498.45	498.45	498.45	498.45	498.45	498.45	498.45
	D			1.866	3.478	7.550	3.273	0.994	4.667	5.667															
Projet	Z		498.33	498.33	498.30	498.30	498.25	498.25	498.37	498.37	498.37	498.37	498.45	498.45	498.45	498.45	498.45	498.45	498.45	498.45	498.45	498.45	498.45	498.45	498.45
	D			1.866	3.478	7.550	3.273	0.994	4.667	5.667															
Ecart entre Projet - Terrain			-0.01	-0.11	-0.06	-0.01	-0.01	-0.01	-0.03	-0.07	-0.00	-0.00	-0.00	-0.00	-0.00	-0.00	-0.00	-0.00	-0.00	-0.00	-0.00	-0.00	-0.00	-0.00	
BBSG	Z		498.33	498.33	498.30	498.30	498.25	498.25	498.37	498.37	498.37	498.37	498.45	498.45	498.45	498.45	498.45	498.45	498.45	498.45	498.45	498.45	498.45	498.45	498.45
	D			1.866	3.478	7.550	3.273	0.994	4.667	5.667															
GB	Z		498.33	498.33	498.30	498.30	498.25	498.25	498.37	498.37	498.37	498.37	498.45	498.45	498.45	498.45	498.45	498.45	498.45	498.45	498.45	498.45	498.45	498.45	498.45
	D			1.866	3.478	7.550	3.273	0.994	4.667	5.667															
Dalles	Z		498.33	498.33	498.30	498.30	498.25	498.25	498.37	498.37	498.37	498.37	498.45	498.45	498.45	498.45	498.45	498.45	498.45	498.45	498.45	498.45	498.45	498.45	498.45
	D			1.866	3.478	7.550	3.273	0.994	4.667	5.667															
GNT 20	Z		498.33	498.33	498.30	498.30	498.25	498.25	498.37	498.37	498.37	498.37	498.45	498.45	498.45	498.45	498.45	498.45	498.45	498.45	498.45	498.45	498.45	498.45	498.45
	D			1.866	3.478	7.550	3.273	0.994	4.667	5.667															
Fond de forme	Z		498.33	498.33	498.30	498.30	498.25	498.25	498.37	498.37	498.37	498.37	498.45	498.45	498.45	498.45	498.45	498.45	498.45	498.45	498.45	498.45	498.45	498.45	498.45
	D			1.866	3.478	7.550	3.273	0.994	4.667	5.667															

Carnet de profils en travers - RD

Axe : Axe
 N° profil : 145
 Pk : 386.931m

Z Tn : 498.43
 Z Projet : 498.44

Section remblais : 0.0
 Section déblais : 3.62

Echelle X : 1/50
 Echelle Z : 1/50

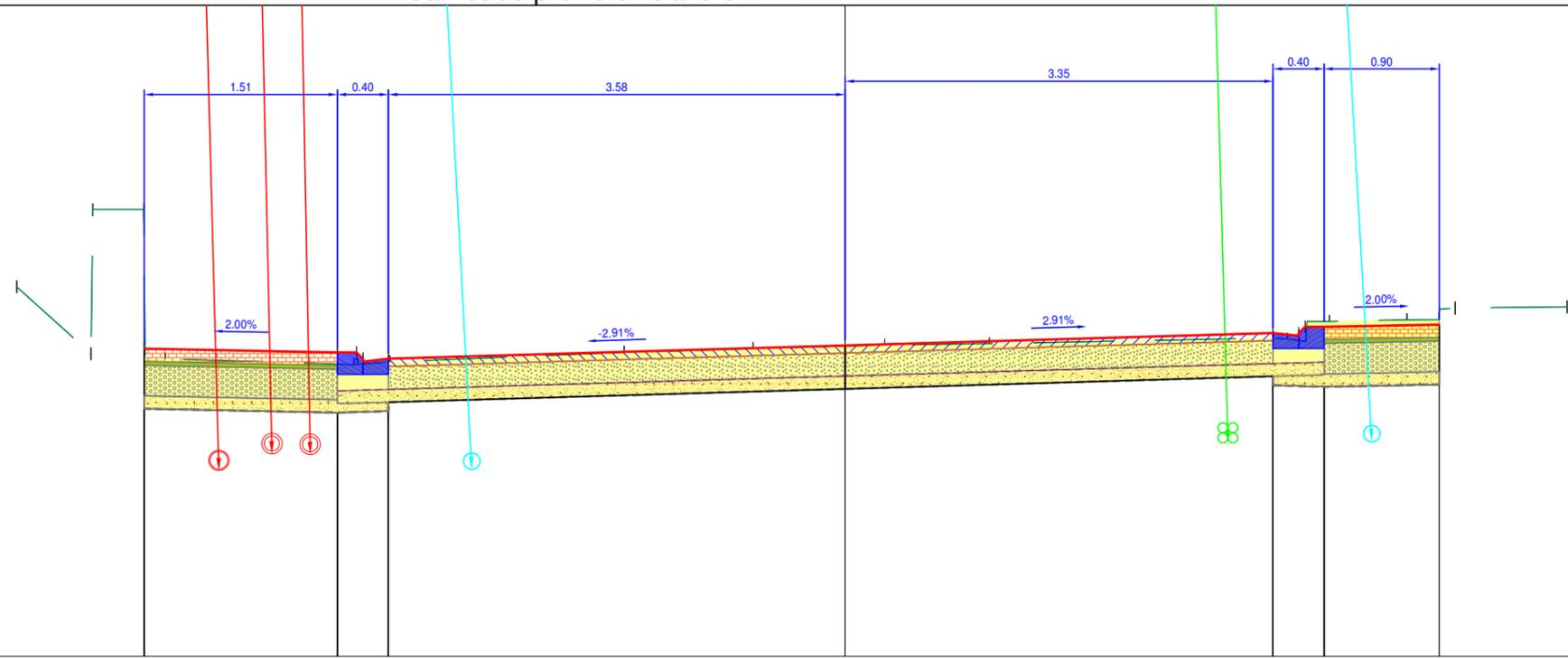

Plan Comp : 496.0

Terrain	Z	-6.493	-498.90	-5.910	498.37	-5.896	499.50	-5.497	499.50	-5.328	498.33	-3.848	498.29	-3.822	488.29	-3.569	498.31	-1.733	498.38	-0.723	498.41	0.000	498.43	0.310	498.44	1.130	498.45	3.356	498.50	3.465	498.49	3.610	498.47	3.793	498.63	4.401	498.64	4.651	498.64	4.789	488.73	5.656	498.74				
	D	0.584		0.399		1.480						1.836						1.009		0.723		0.310		0.820			2.226					0.608															
GC	Z																																														
	D					1.514															7.733																										
Projet	Z																																														
	D					1.514																																									
Ecart entre Projet - Terrain																																															
BBSG	Z																																														
	D																																														
GB	Z																																														
	D																																														
Dalles	Z																																														
	D					1.514																																									
GNT 20	Z																																														
	D					1.514																																									
Fond de forme	Z																																														
	D					1.514																																									

